

Connect XL[®]

Single landscape Manual

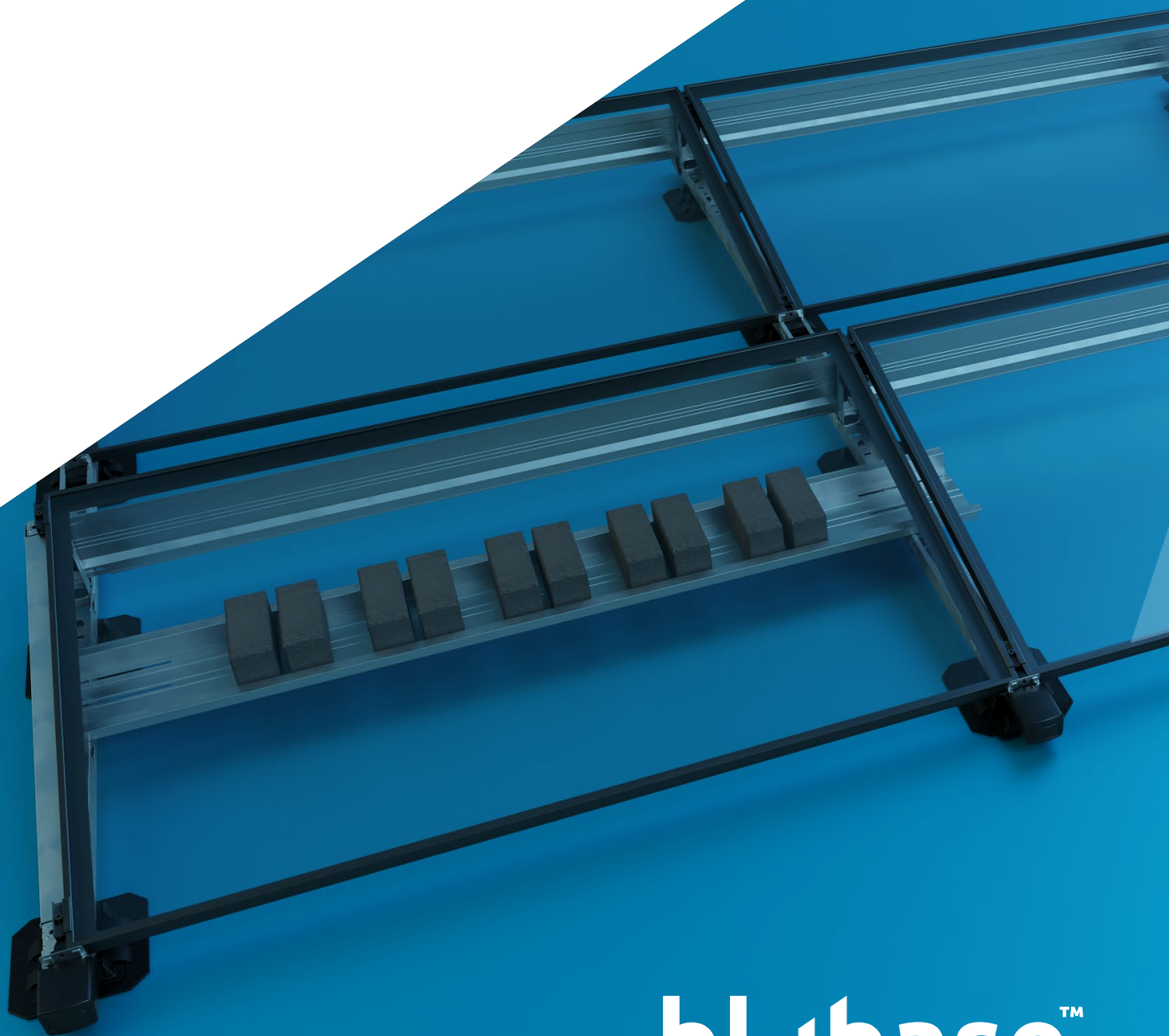

blubase[™]
STRONG IN SOLAR SUPPORT

TABLE OF CONTENTS

INTRODUCTION	3
About this document	3
Other relevant documents	3
Symbols used in this manual	4
WARRANTY AND LIABILITY	4
Warranty	4
Liability	4
PRODUCT INFORMATION	5
Intended use	5
Specifications	5
Requirements for the work environment	5
SYSTEM AND APPLICATION	6
1. Components	6
SAFETY	7
1. Personal protective equipment	7
2. Safety warnings and regulations	7
INSTALLATION	8
1. Preparation	8
2. Place the base elements	10
3. Place ballast	14
4. Mounting the first solar panel	17
5. Mounting the following solar panels	19
6. Placing back plates	21
7. Installing side deflectors	23
8. Placing end caps	24
ANNEXES	25
A. CABLE MANAGEMENT	25
B. SPARE PARTS LIST	26

INTRODUCTION

ABOUT THIS DOCUMENT

This manual covers the installation instructions for the Blubase Connect XL mounting system for solar panels on flat roofs with roofing materials made of concrete, bitumen, EPDM, and PVC. For other roof materials, please contact your supplier.

The mounting system is suitable for mounting solar panels in a single landscape orientation.

These instructions are addressed at qualified technical personnel.

You can download the latest version of this manual from www.blubase.com.

OTHER RELEVANT DOCUMENTS



When installing the Blubase Connect XL mounting system, you will need the following documents in addition to this manual:

- The project plan, which you can create in the calculator at <https://calculator.blubase.com>.
- The installation manuals for the solar panels, inverters and any other components.

During the installation of the mounting system, it is important to adhere to the installation manual, the installation manual of the components, and the accompanying standards to prevent accidents. Pay special attention to (local) standards, regulations and legislation (among others):

- Local Building Regulations (latest version)
- Health and Safety at Work etc Act 1974
- Health and Safety in Roof work - HSE
- Eurocodes 0 (EN 1990 - Structural Design)
- Eurocodes 1 (EN 1991 - (Influences on structures)
- HD-IEC 60364 series - Electrical installations for low voltage
- EN-IEC 62305-2 - Protection lightning - Risk Management
- MIS 3002 – The solar PV standard
- MCS012 - Product Certification Scheme Requirements: Pitched Roof Installation Kits

SYMBOLS USED IN THIS MANUAL

	Warning!	Failure to follow this instruction could result in serious injury or major damage to the product.
	Caution!	Failure to follow this instruction could result in personal injury or damage to the product.
	Note	Emphasises an instruction.

WARRANTY AND LIABILITY

WARRANTY

Blubase extends a 20 year product warranty. The warranty is subject to the warranty terms and general terms & conditions of Blubase. These can be found on the website www.blubase.com.

LIABILITY

Blubase accepts no liability for damage or injury caused by the failure to comply (strictly) with the safety guidelines and instructions in this manual, or by negligence during installation of the product and the accessories listed in this document.



Blubase reserves the right to change this document without notice.

PRODUCT INFORMATION



INTENDED USE

The Blubase Connect XL Single mounting system is intended for mounting solar panels on flat roofs. With this mounting system you can install solar panels with the long side at the bottom (landscape). The mounting system is intended to be installed in a single arrangement.

SPECIFICATIONS

Orientation of solar panels	Landscape
Frame height of solar panel	30 & 35 mm
Maximum dimensions of solar panels	Length: 1663 mm - 2126 mm Width: 1130 mm - 1150 mm
Maximum field size	20 × 20 panels per segment
Roof material	Concrete Bitumen EPDM PVC
Roof pitch	0 - 5°  If your roof slope is > 5°, please contact your supplier.
Maximum roof height	 Subject to Eurocode guidelines and national additions. Use the calculator to calculate the possibilities of your project.
Edge zone	 Calculate the edge zone with the calculator.

REQUIREMENTS FOR THE WORK ENVIRONMENT

	The roof is in good condition. When in doubt, contact an expert for an inspection.
	The roof construction has sufficient bearing capacity to support the installation, taking into account wind and snow loads. When in doubt, contact a construction engineer.

SYSTEM AND APPLICATION

1. COMPONENTS

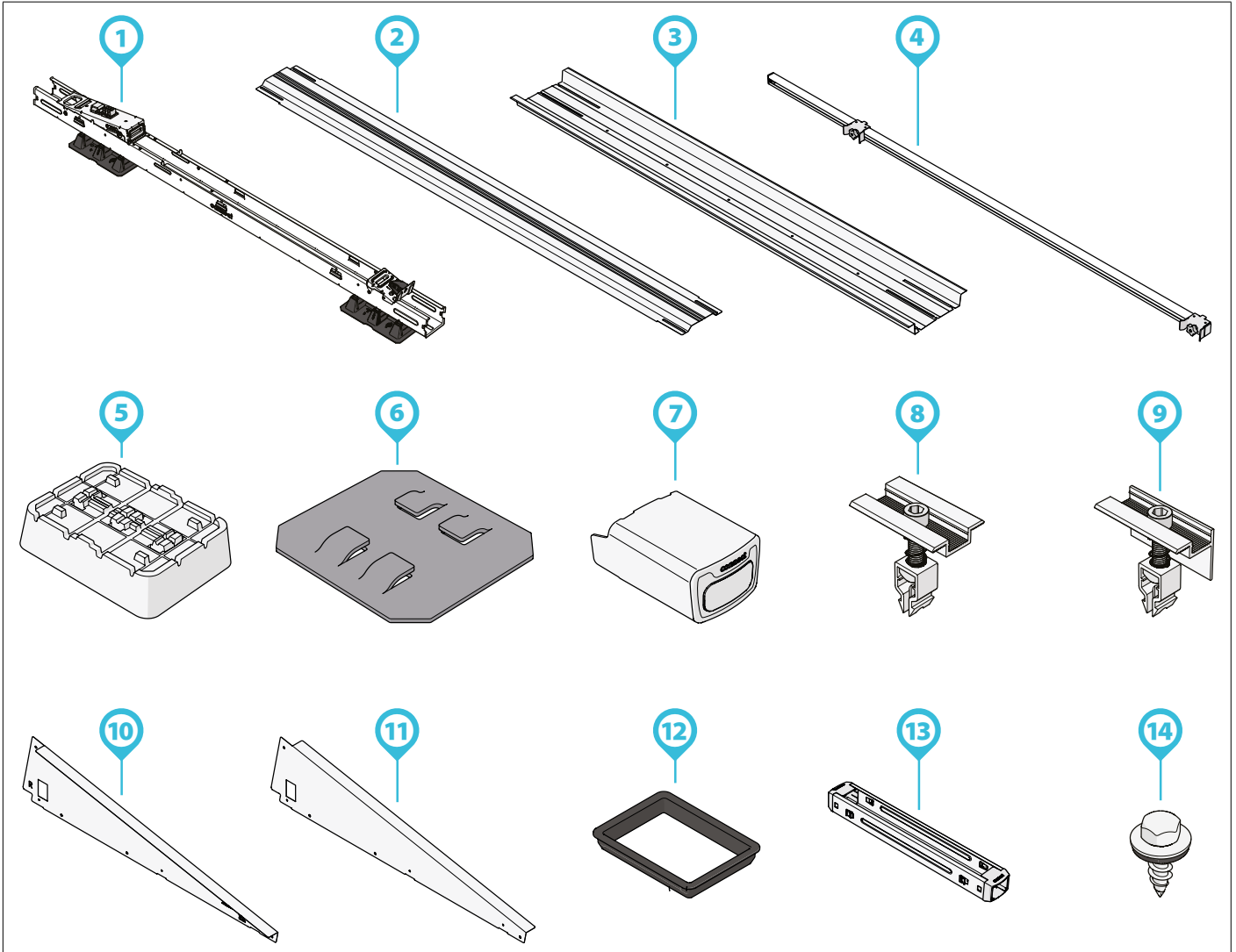







Component

- | | |
|----------------------------|-------------------------------------|
| 1) Connect XL base element | 8) Easy mid clamp |
| 2) Connect back plate | 9) Easy end clamp |
| 3) Connect ballast tray | 10) Connect XL side deflector left |
| 4) Connect Solarsteller | 11) Connect XL side deflector right |
| 5) Connect leveling block | 12) Connect cable grommet |
| 6) Connect friction mat | 13) Connect coupler |
| 7) Connect end cap | 14) Connect cladding screw |

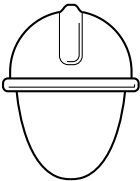
i Check that the correct components are present in the required numbers according to the project plan generated by the calculator.



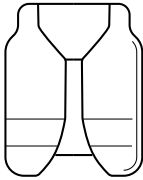



SAFETY

1. PERSONAL PROTECTIVE EQUIPMENT



			
Hearing protection	Safety helmet	Safety glasses	Face masks
			
Safety gloves	Safety clothing	Safety shoes	

2. SAFETY WARNINGS AND REGULATIONS

Warning!

-  Installation work should always be carried out by at least two people.
-  Do not use components from other mounting systems.
-  Do not leave out parts.
-  Always work according to the current regulations for working on roofs.
-  Do not perform the installation in strong winds, or when the roof is slippery or wet.
-  Always work on the roof with fall protection and, if necessary, with safety nets and edge protection.
-  Always use a lifting aid or hoisting device when moving heavy equipment.

Caution!

-  Never walk on the system or on the solar panels.
-  Blubase is in no way responsible for the installation and/or connection of lightning protection on the roof. Get expert advice from your specialist and ensure that a safe installation can be guaranteed according to EN-IEC 62305 and HD-IEC 60364.

INSTALLATION

1. PREPARATION

1 Inspect the roof.	
<input type="checkbox"/>	The roof is in good condition.
<input type="checkbox"/>	The roof construction has sufficient bearing capacity to support the installation, taking into account wind and snow loads.

2 Check the project plan and components.	
<input type="checkbox"/>	Check the project plan.
<input type="checkbox"/>	Check that all components are present (page 5).

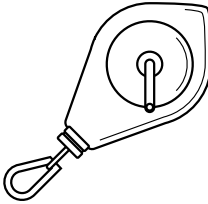
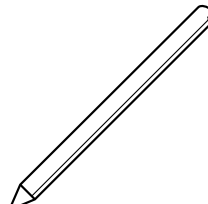
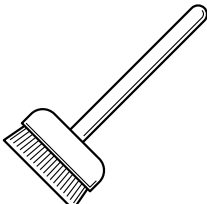
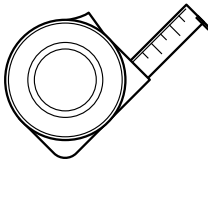
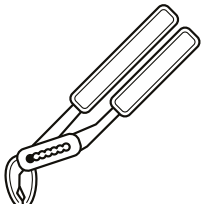
3 Make sure all the required tools are at hand.				
				
Chalkline tool	Marker or chalk	Broom	Tape measure	Water pump pliers

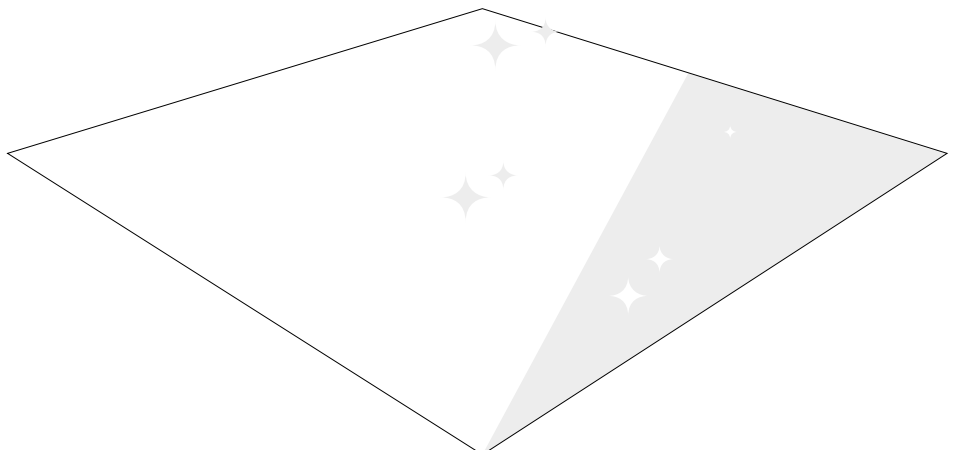
4 Clean and tidy the roof.

5 Draw the lines of the field and make note of the orientation of the north arrow.

- i** Use the 3-4-5 rule to make sure the angle between your perpendicular lines is 90 degrees.
- i** Consult the project plan to determine the position of the base elements for your project.
- i** Take the starting point of the installation from the project plan.

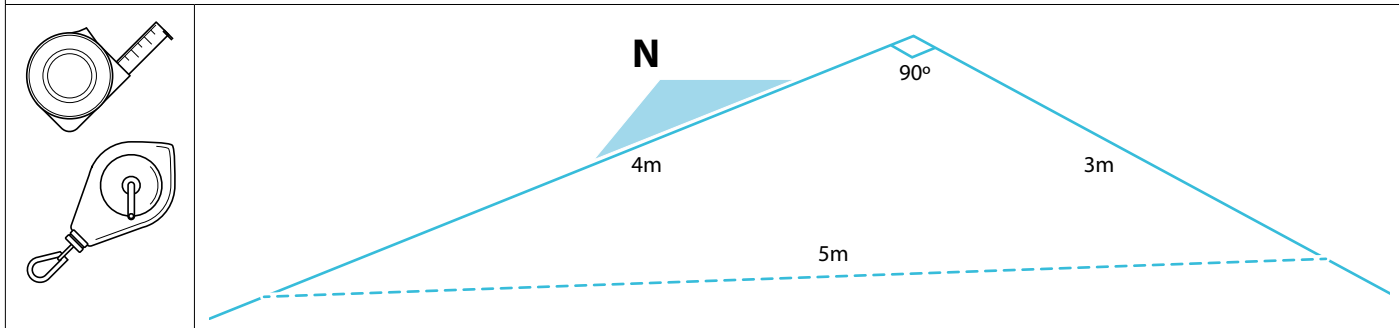

6 Mark the position of the first Connect XL base element.

- i** Be mindful of the edge zone. Consult the project plan to determine the position of the first base element.

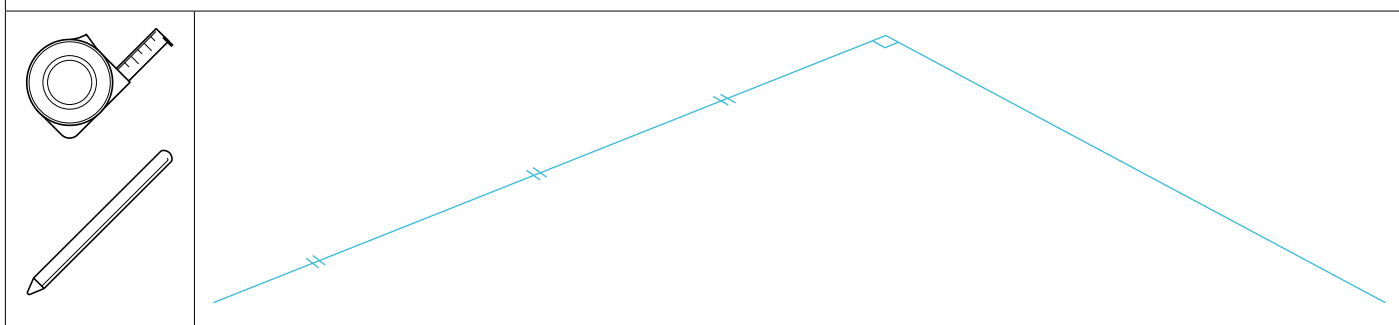

7 Align the brackets of the Solarsteller to the corners of a solar panel.

8 Duplicate the distance for all Solarstellers.

- i** Tip: often, six Solarstellers are used to easily align and install the base elements.

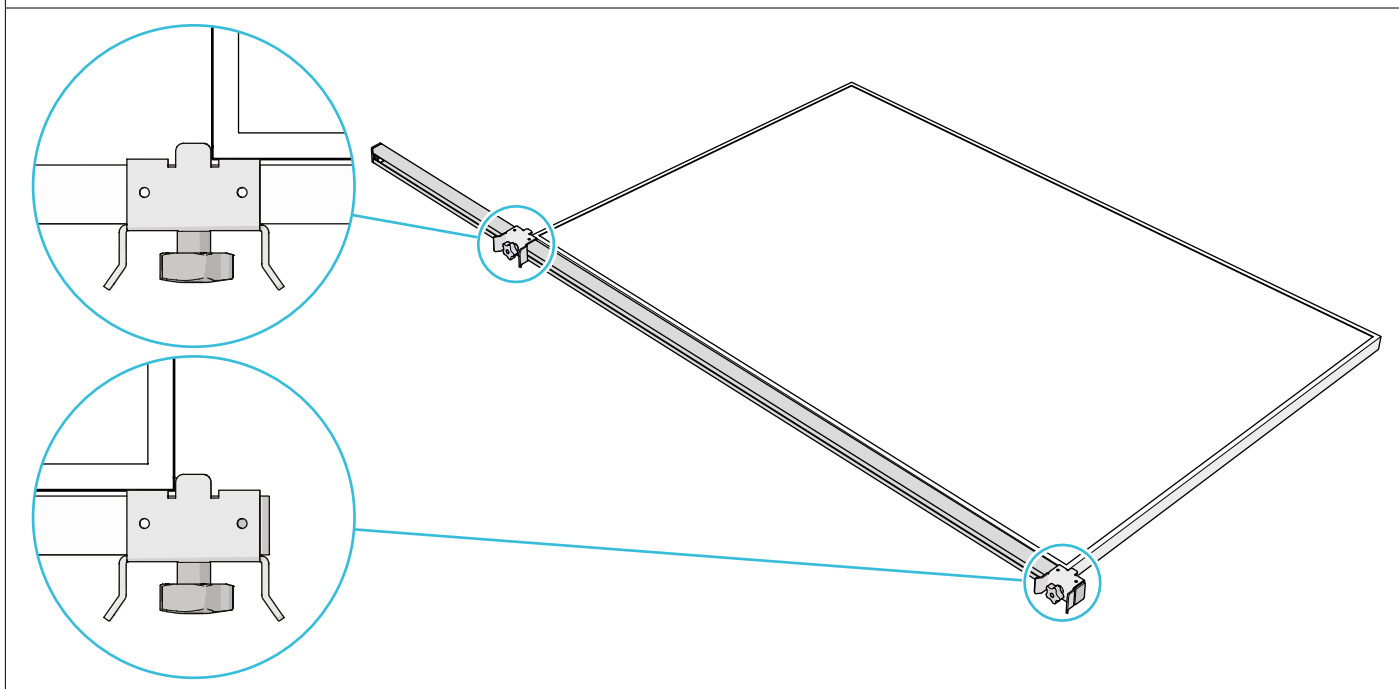

2. PLACE THE BASE ELEMENTS

- 1 Place the first base element on the roof and align the base element with the marked lines.

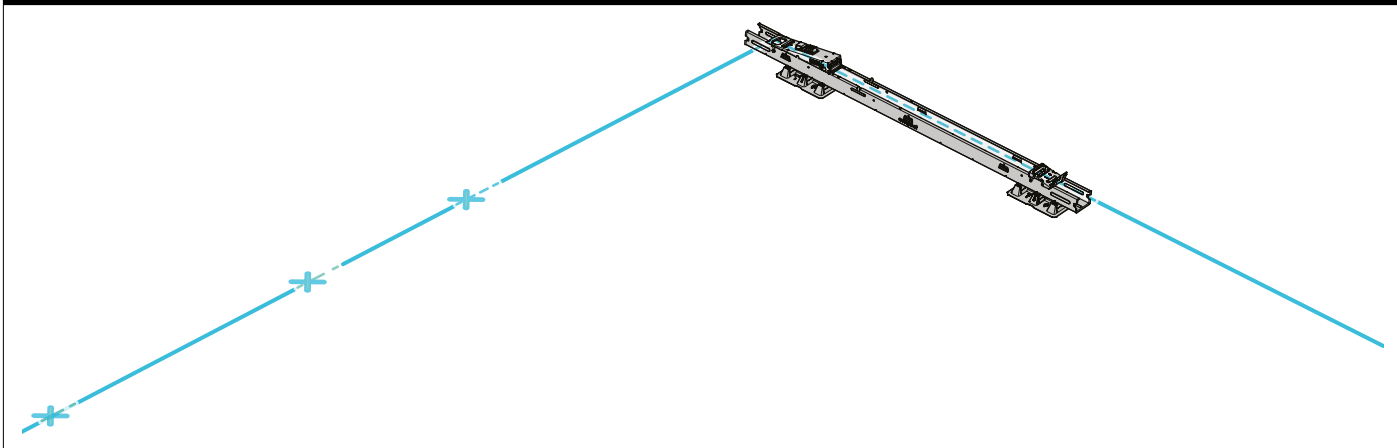

- 2 Optional: Add friction mats underneath the base plates of each base element.

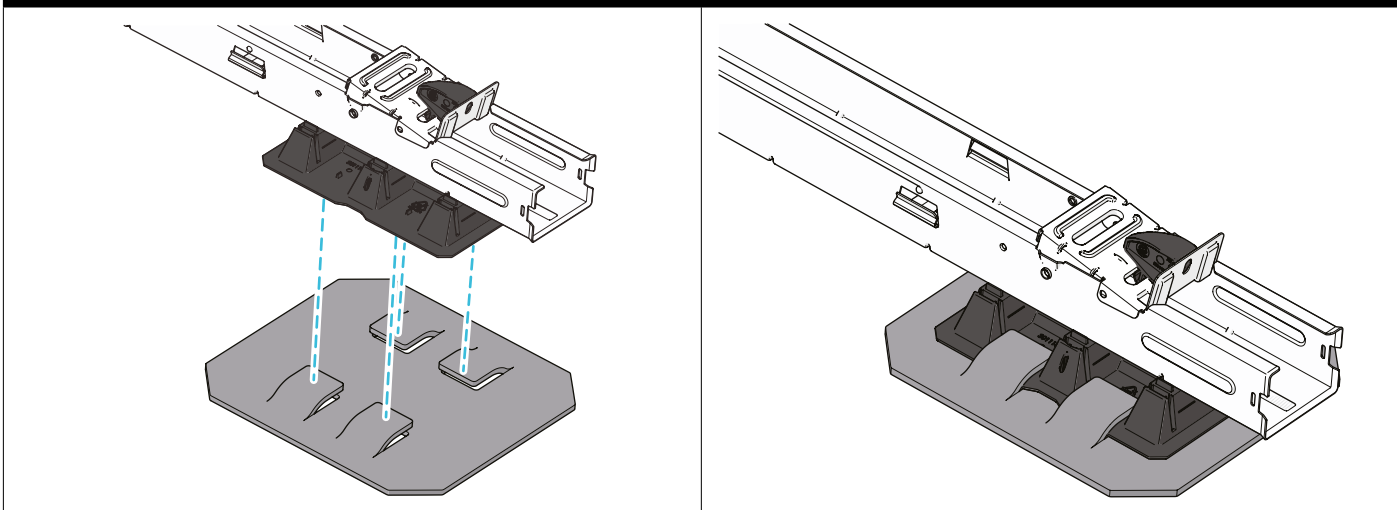

- 3 Situational: Place leveling blocks underneath the feet of each element when installing on roofs with pebbles.
- 4 Make sure the pebbles on the roof are level with the leveling blocks.

! Only use leveling blocks on roofs with pebbles. Do not use leveling blocks to raise the system from the roof, as this heavily increases the wind load on the solar panels.

i Remove all pebbles and debris from the positions of the leveling blocks.

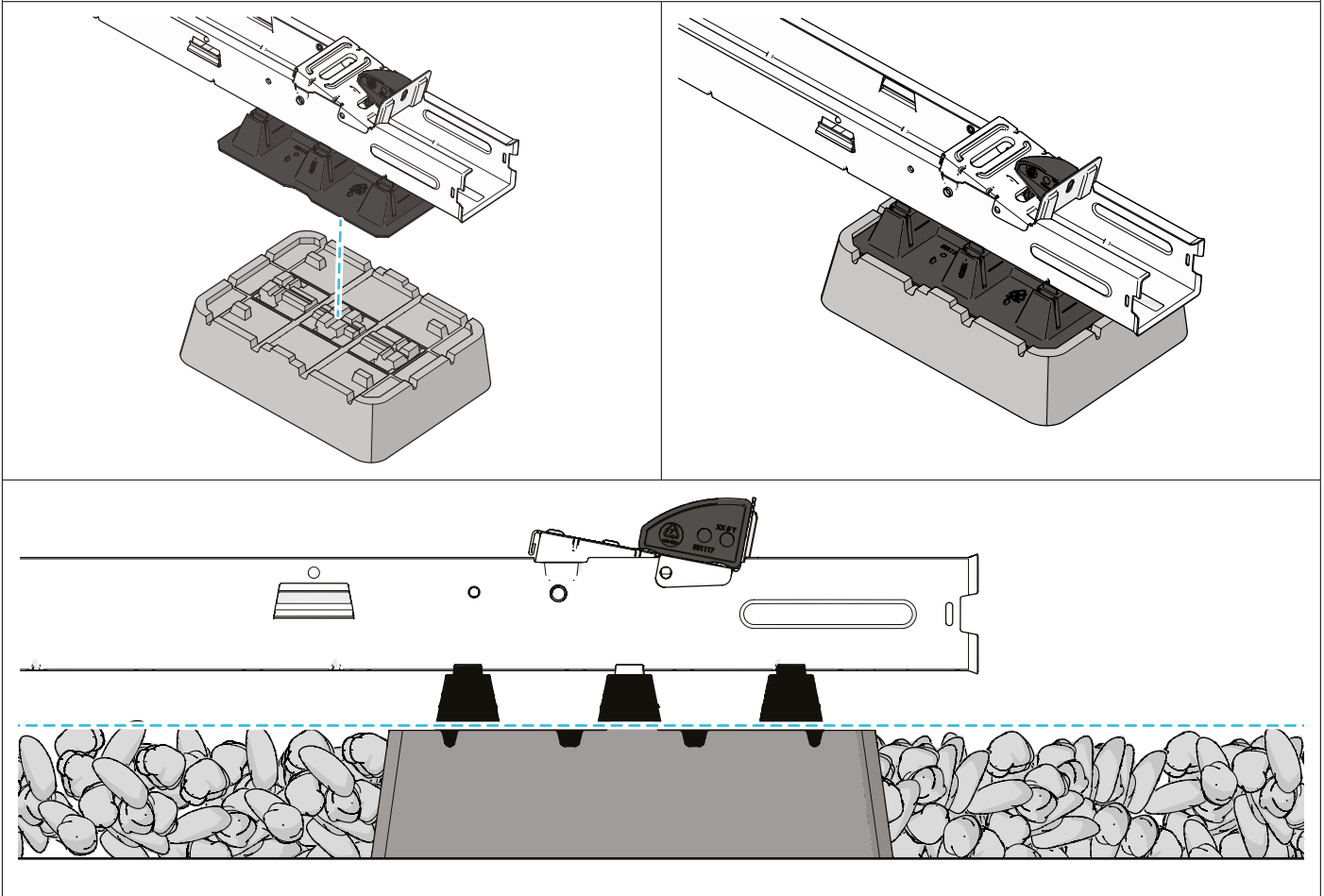

- 5 Tilt up the high base until it clicks into upright position.

! Check that the base element is still aligned with the perpendicular lines.

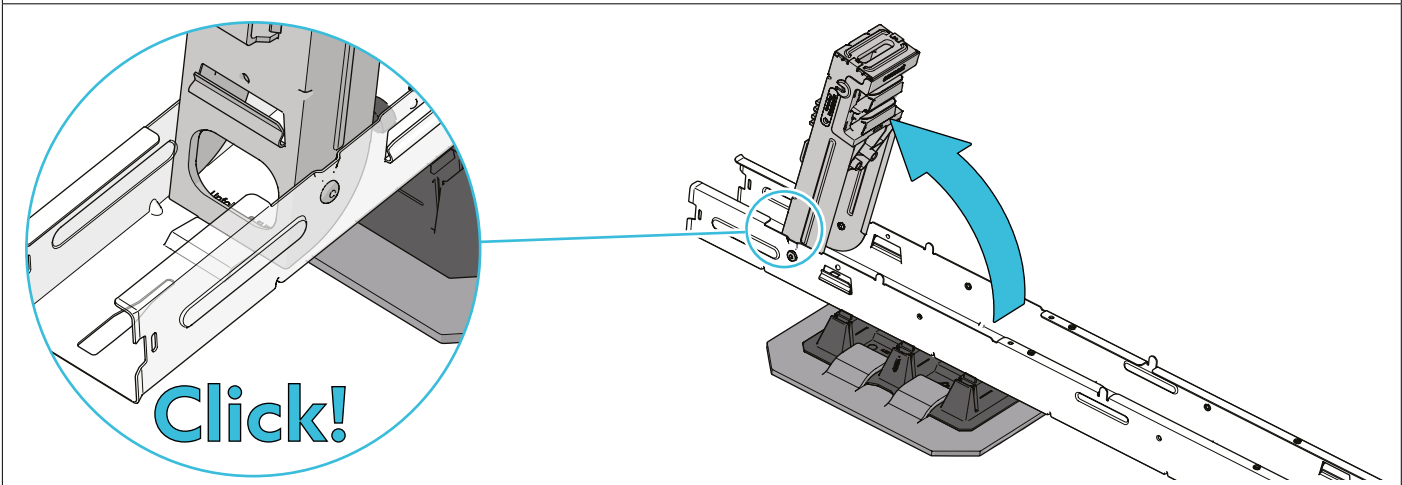

- 6 Place the next base element on the roof.
- 7 Tilt up the high base until it clicks into upright position.

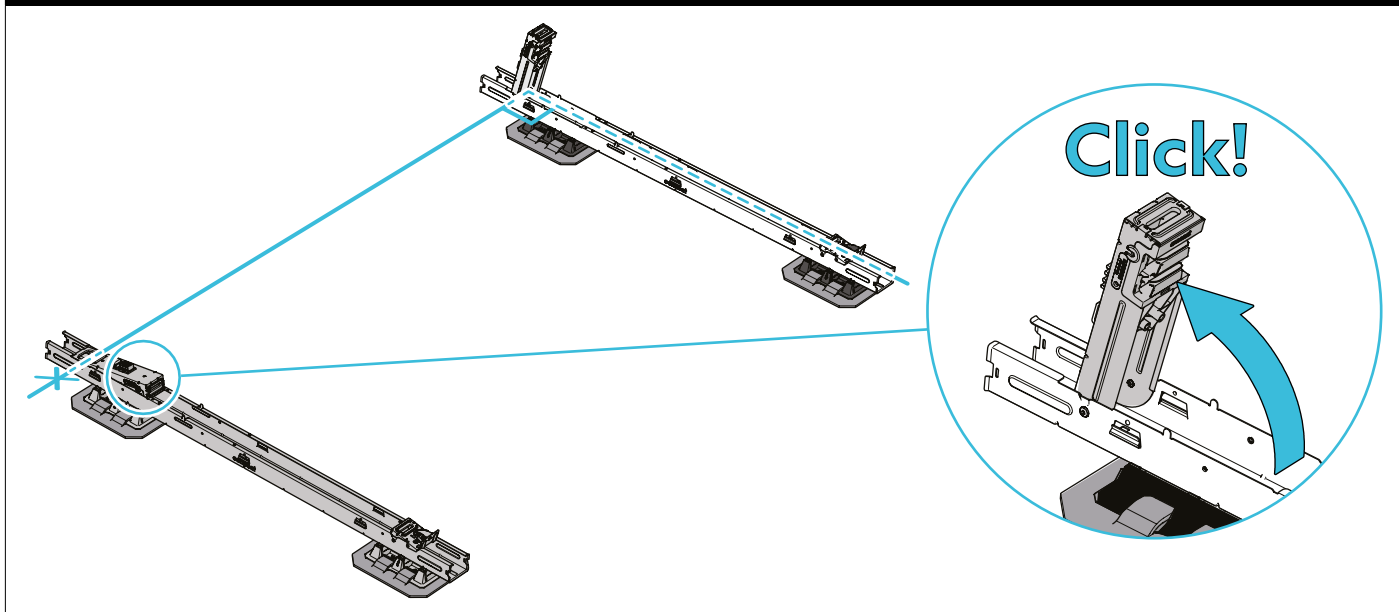

- 8 Use two Solarstellers to align the base elements perpendicular at the correct distance.

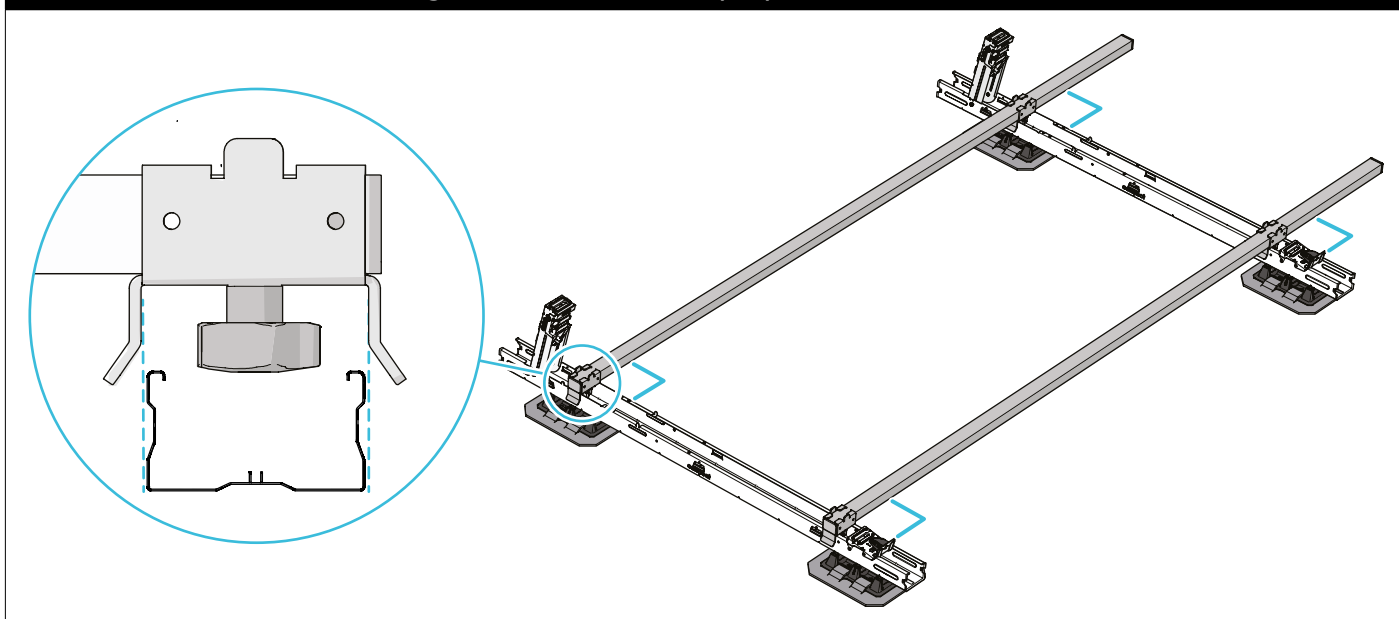

 Repeat steps 2.1. - 2.8. for every module of the row.

9 Extend the segment by inserting the coupler into the end of the base element until it clicks into place.

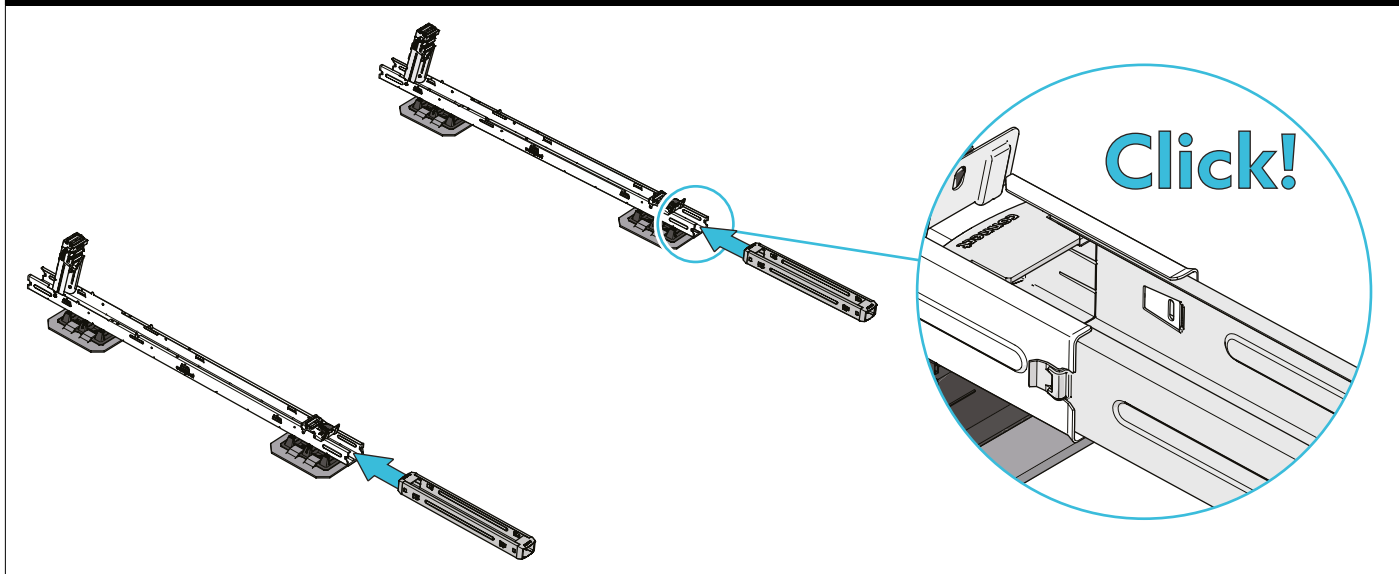

10 Tilt up the high base of the base element until it clicks into upright position.

11 Slide the base element over the coupler until it clicks into place.

! Tip: In this manual, the base elements are installed in south orientation. for east-west orientation, horizontally rotate every second base element 180 degrees.

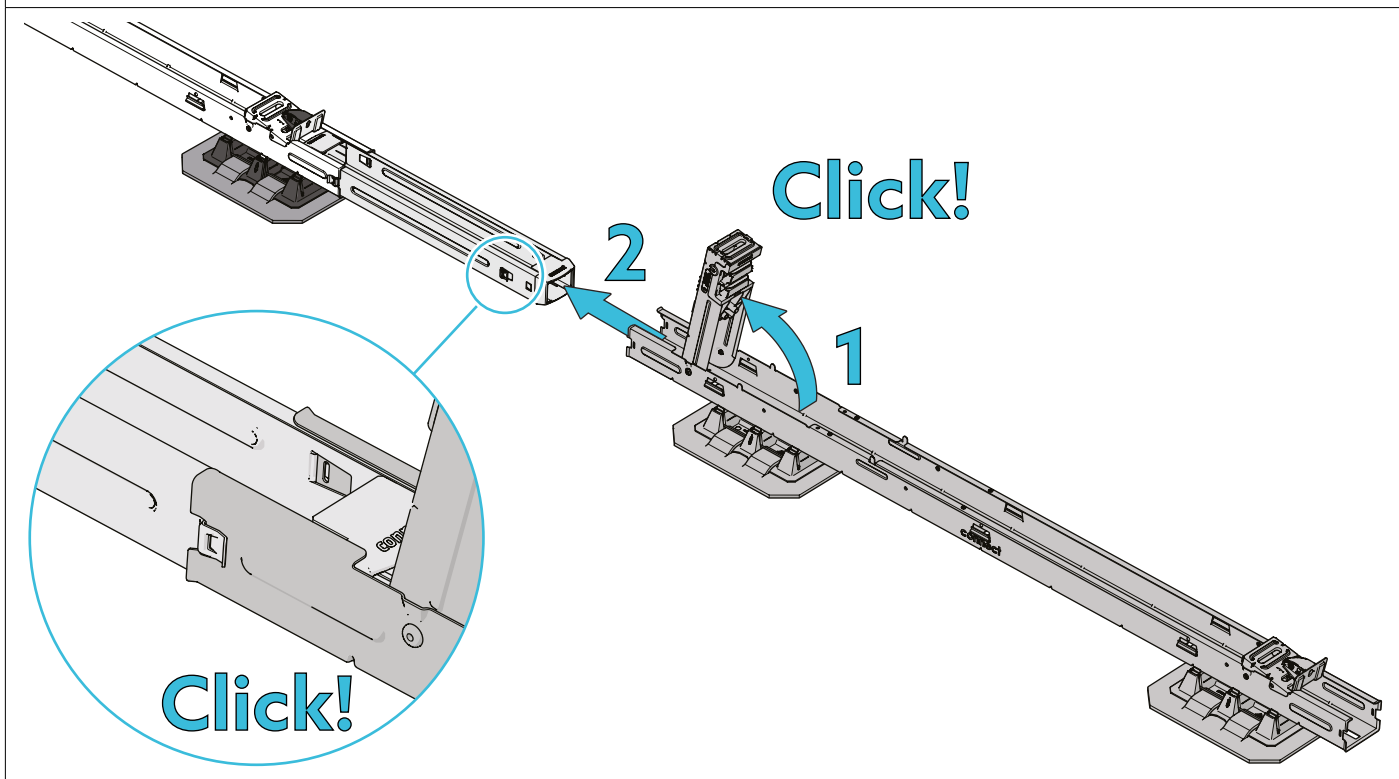

12 Realign the base elements using at least two Solarstellers.

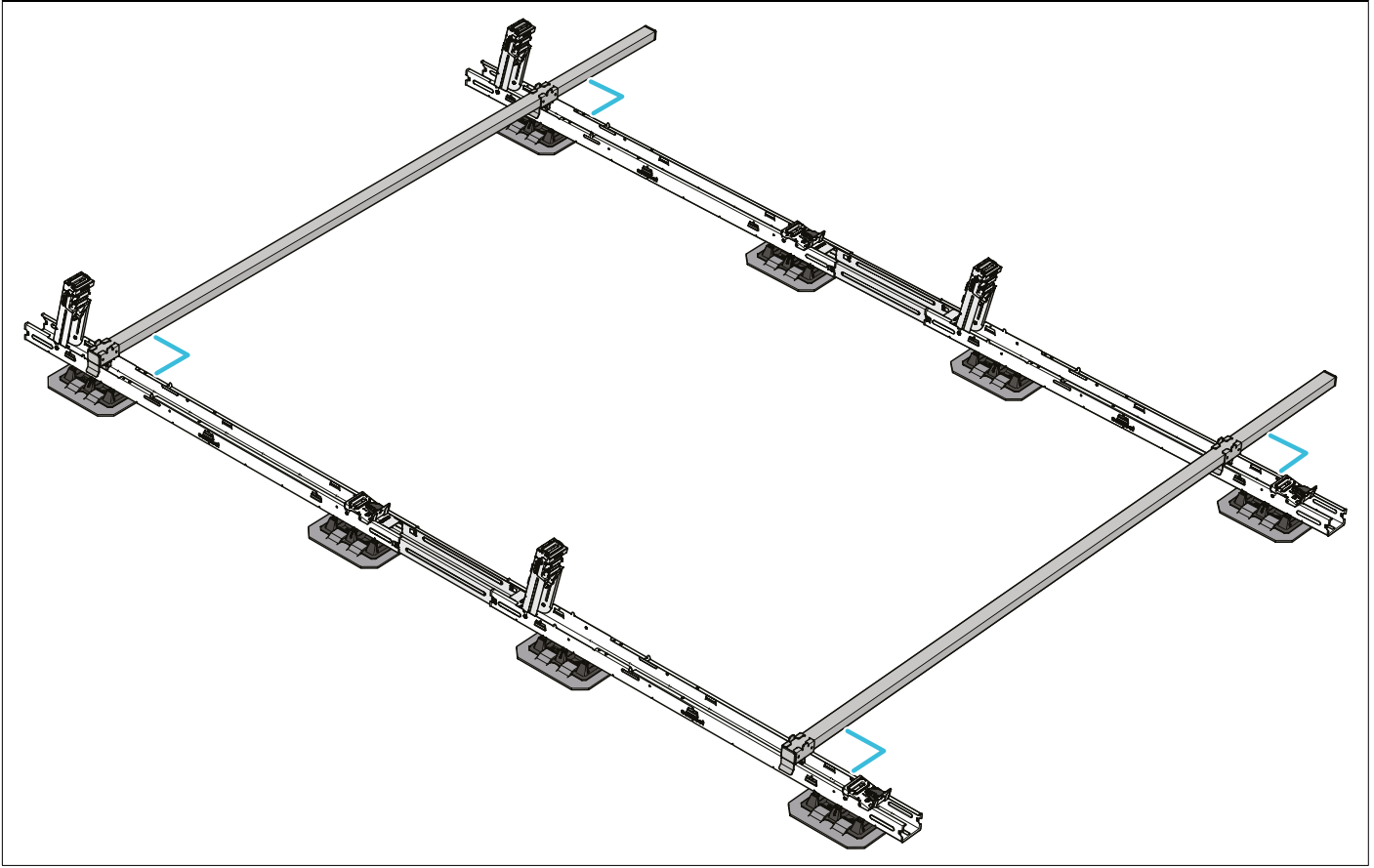

3. PLACE BALLAST

! The calculator determines the ballast needed for your project. Follow the instructions from the project plan determined by the calculator. If anything changes in the layout of the solar panel field, the ballasting has to be recalculated.

- 1 Place the ballast tray over the base element in the position specified in the project plan.
- 2 Align the cut-outs in the ballast tray with the hole and lip of the base element.
- 3 Fix the ballast tray to the module with two screws.

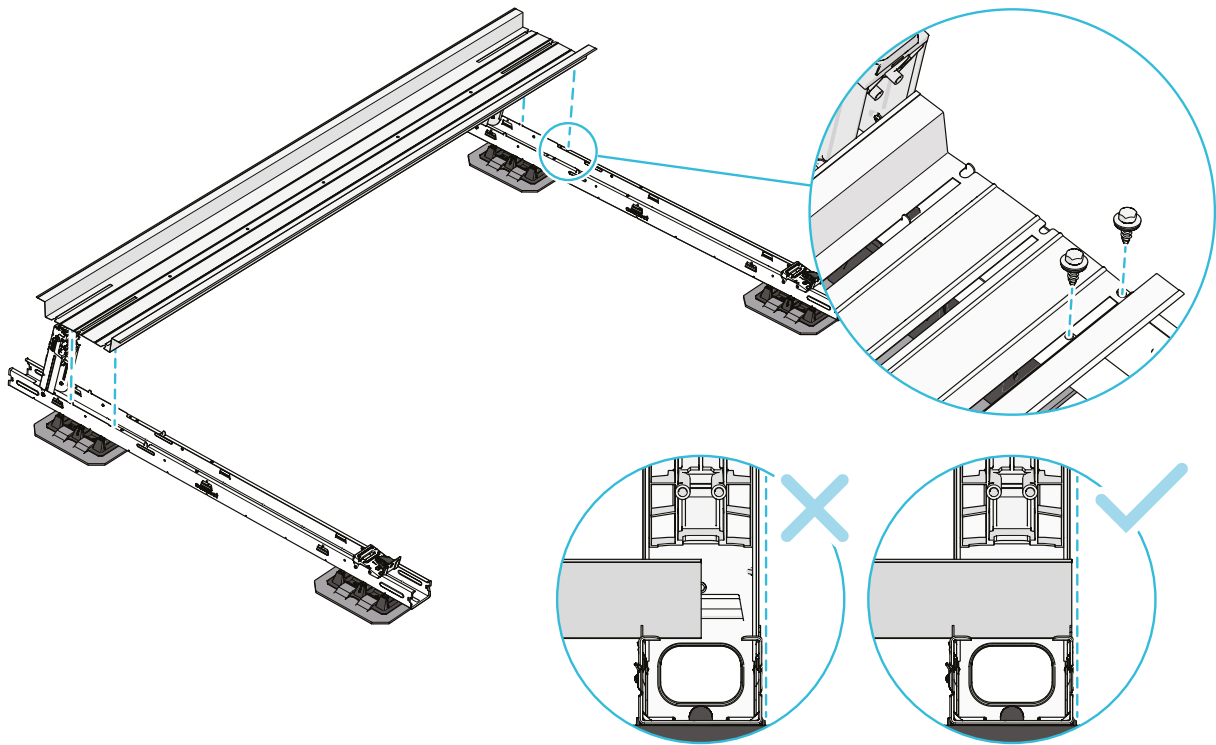

- 4 Situational: Place a second ballast tray in front of the first ballast tray.
- 5 Align the cut-outs in the ballast tray with the hole and lip of the base element.
- 6 Fix the ballast tray to the module with two screws.

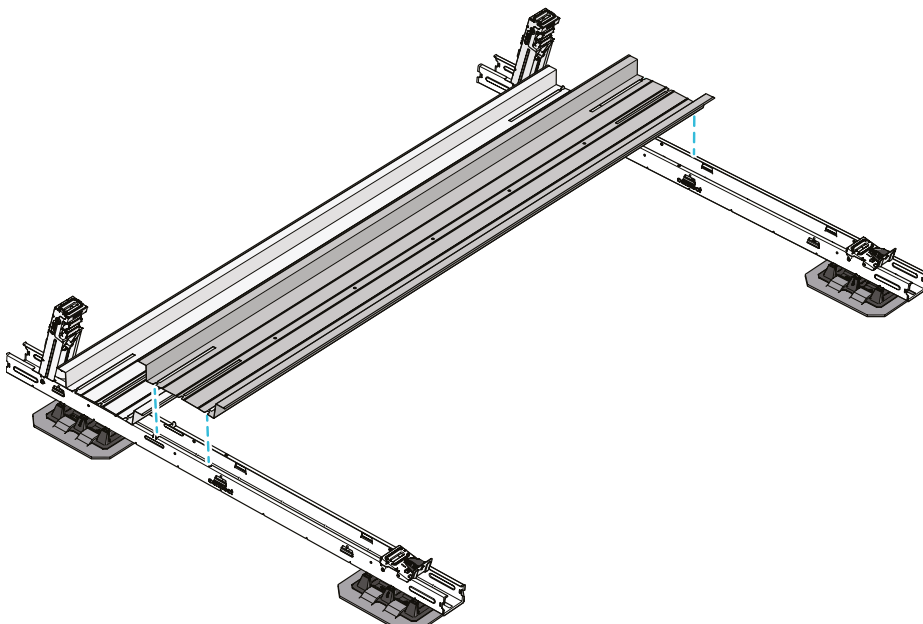

- 7 Place the following ballast tray over the next base element, partially overlapping the first ballast tray.
- 8 Align the cut-outs in the ballast tray with the hole and lip of the base element.
- 9 Fix the ballast tray to the module with two screws.

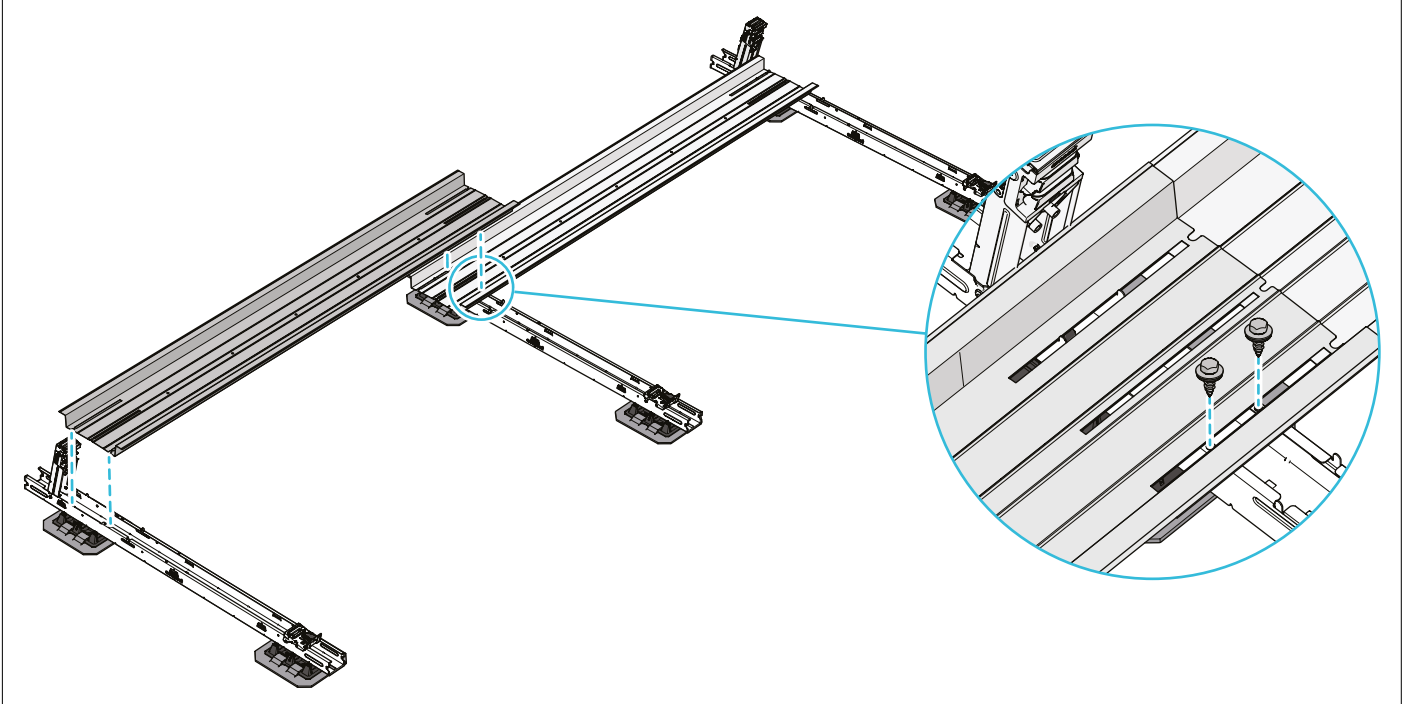

10 Evenly distribute bricks over the ballast trays.

- i** Follow the project plan for the required positions and quantities of ballast.
- i** When using alternative ballast forms, the calculated weight per tray must be met. Additionally, the ballast must be properly contained within the trays at all times.'
- i** Place the bricks in the outer ballast tray on the flat side, otherwise they will not fit under the solar panel.

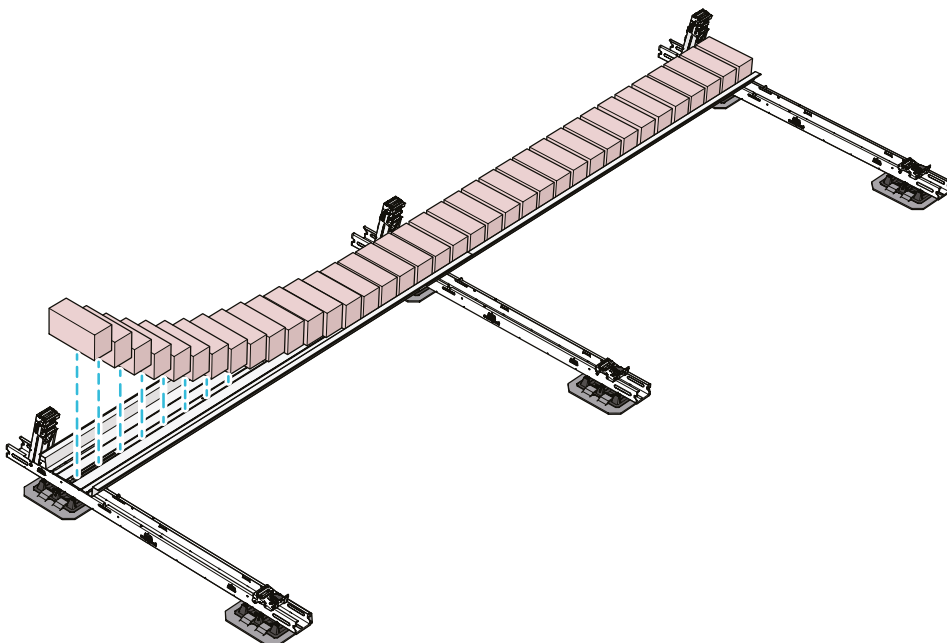

Repeat the steps in this chapter for all base elements.

4. MOUNTING THE SOLAR PANELS

! Do not mount any solar panels if there may be strong winds in the time between mounting the solar panel and wind deflectors. Immediately mount the wind deflectors after mounting a field of solar panels.

1 Place the solar panel upright on two low bases between the guides.

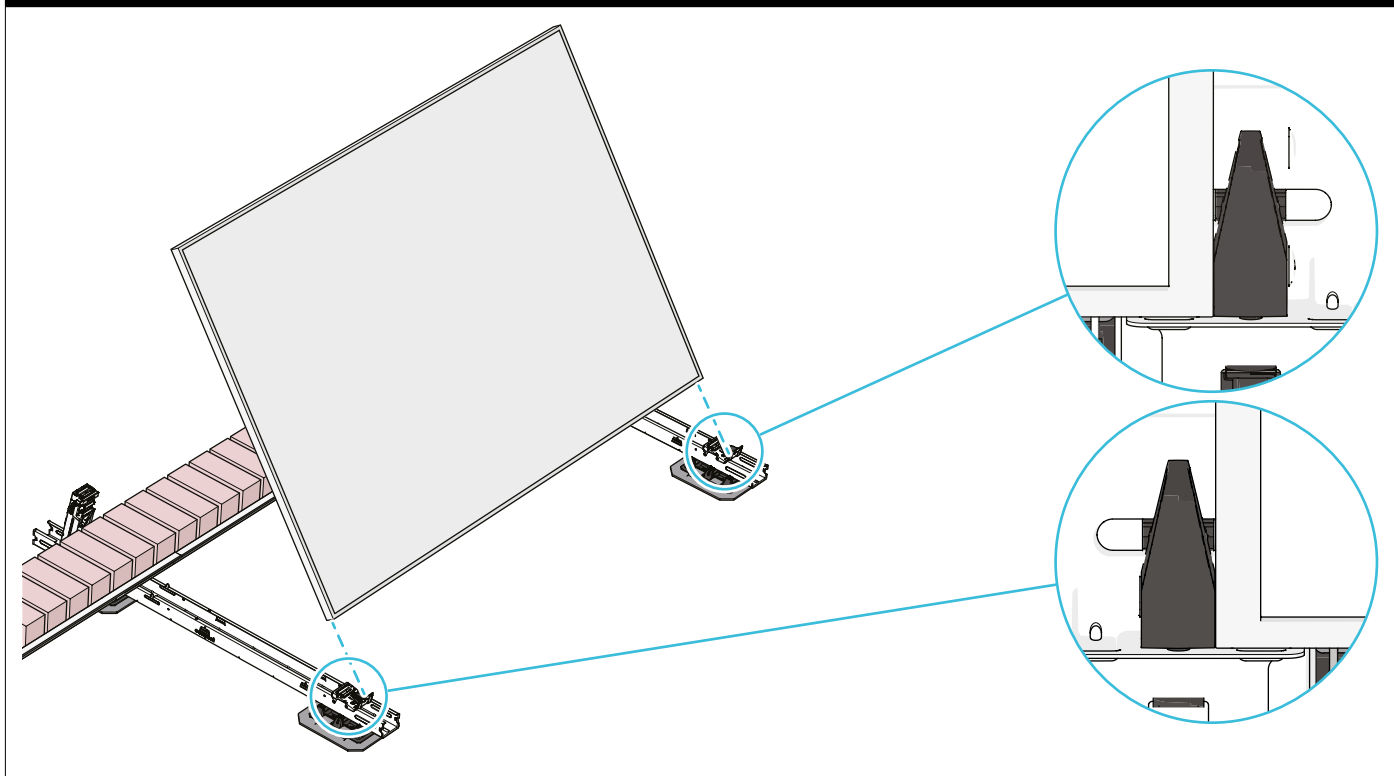

2 Carefully lower the solar panel on the high bases.

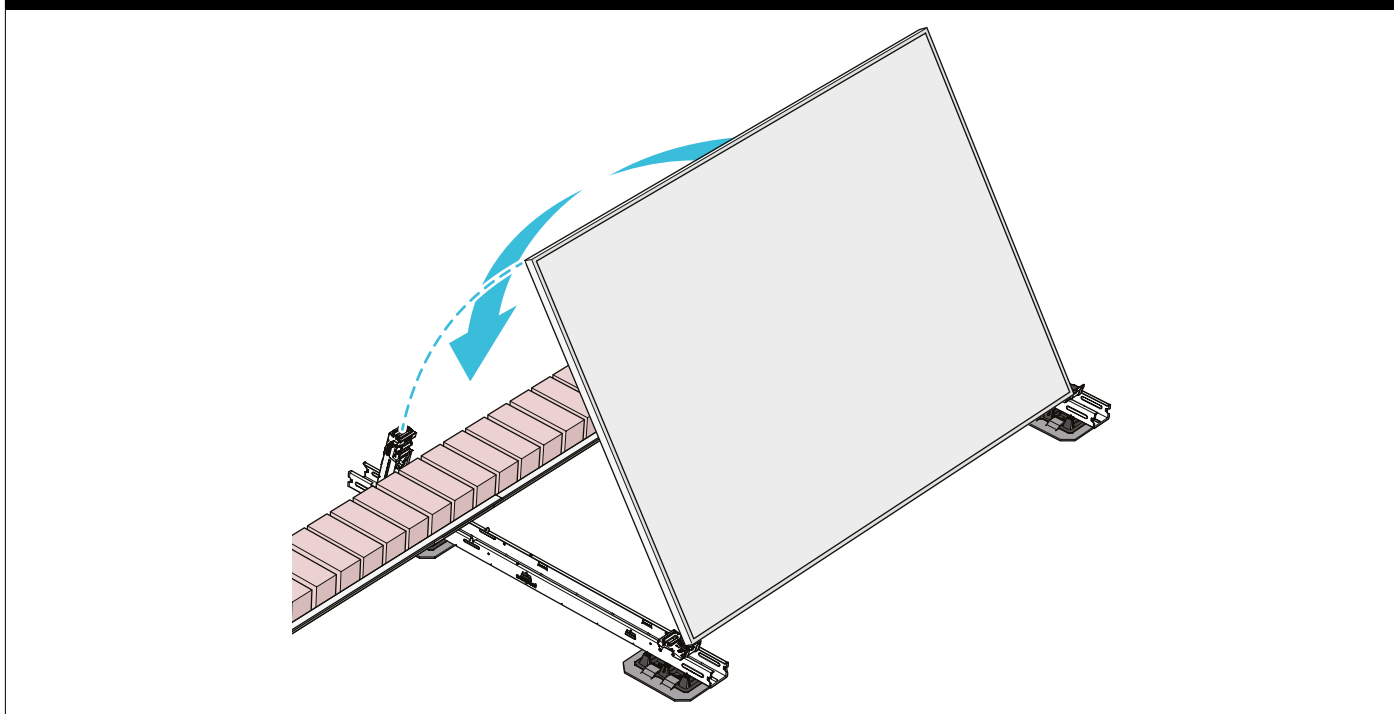

3 Mount the end clamps on the high and low base and tighten the screw using a 8mm hex tool. Apply a torque of 8 Nm.

i See appendix A for cable management instructions.

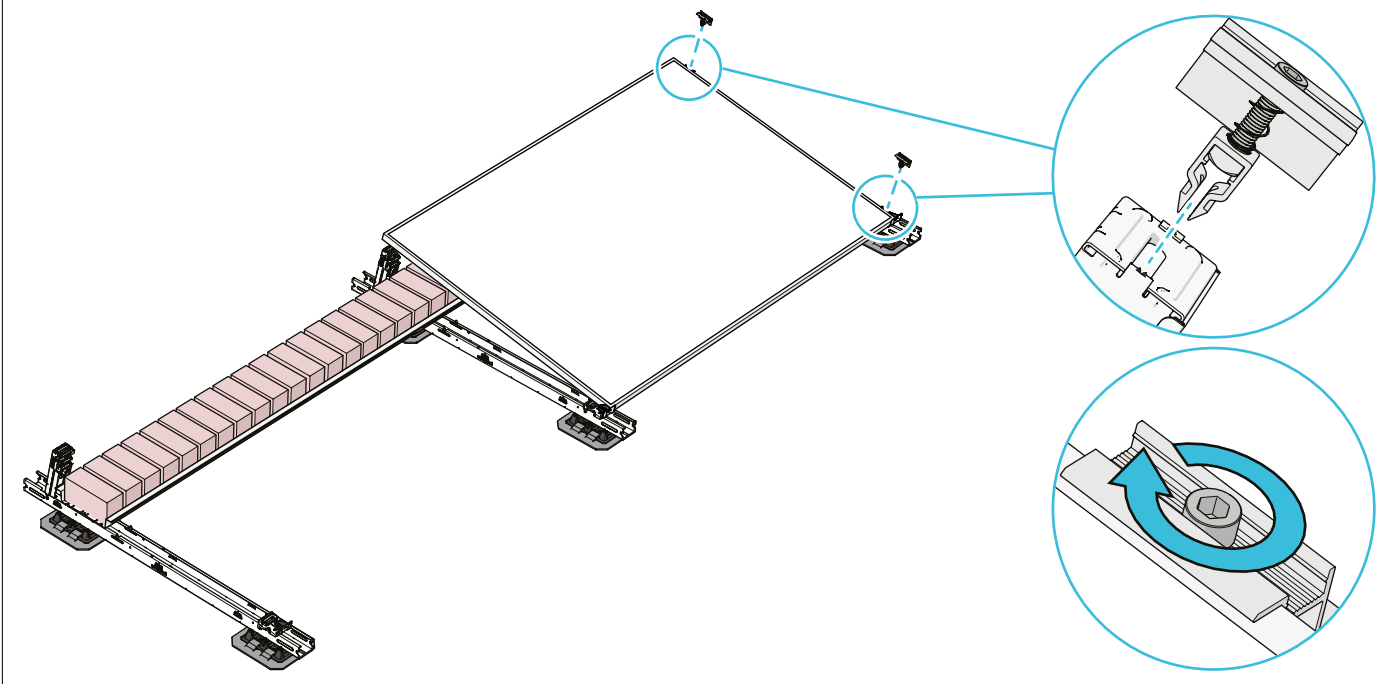

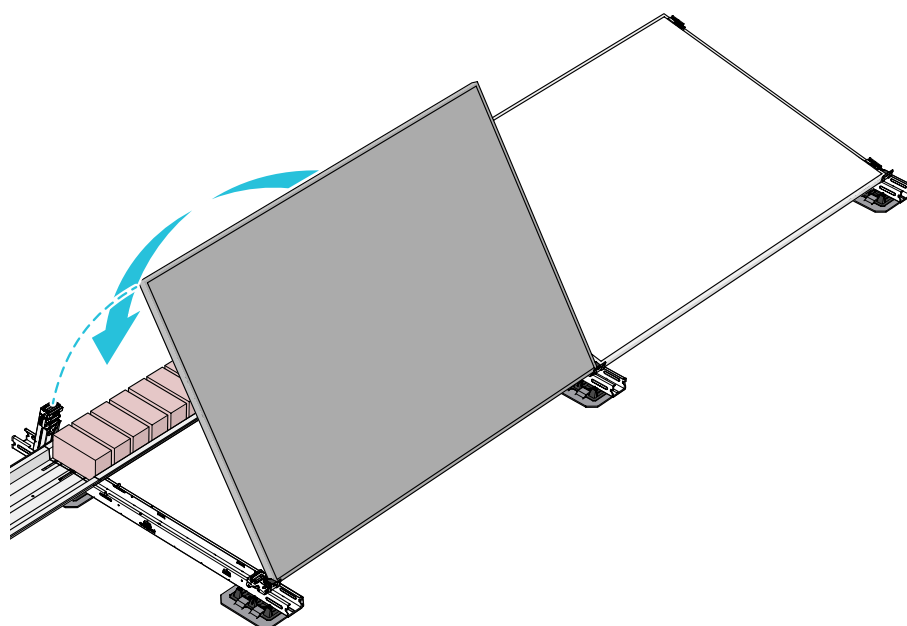

4 Place the solar panel upright on two low bases between the guides.

5 Carefully lower the solar panel on the high bases.

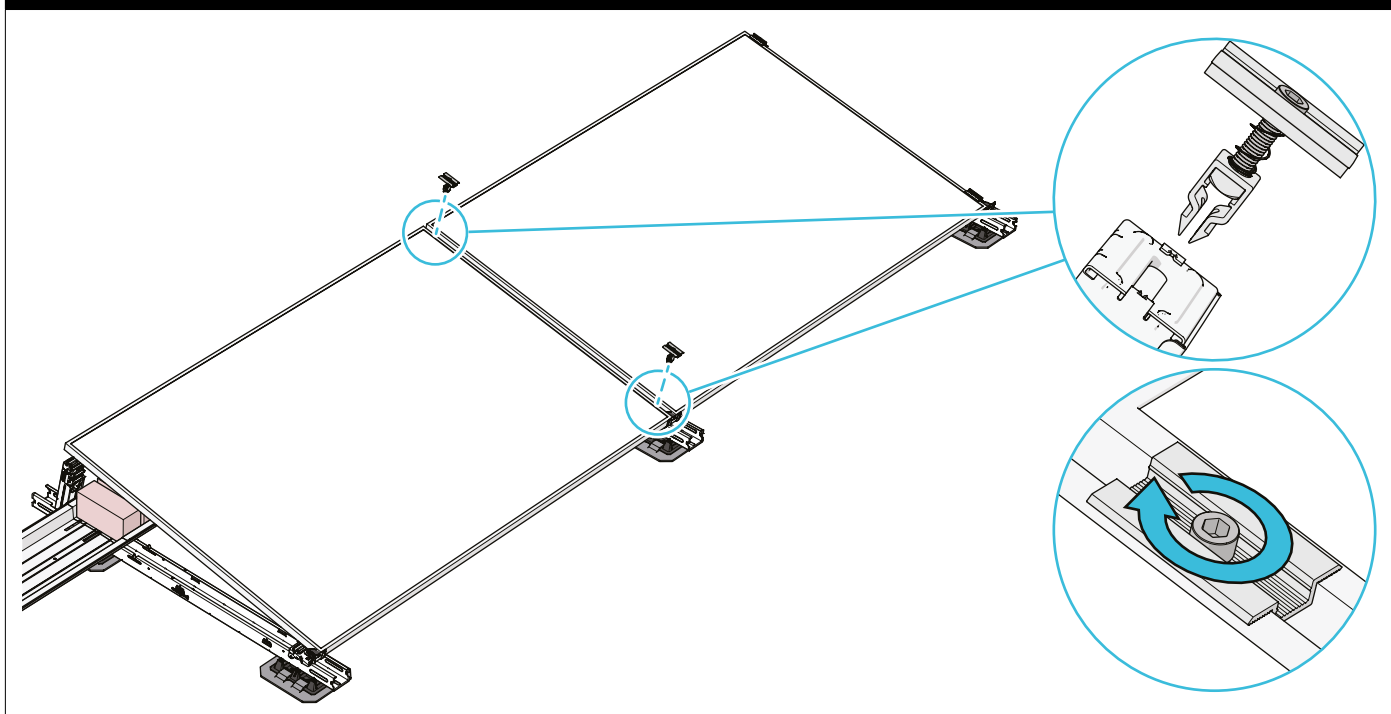

6 Mount the mid clamps on the high and low base and tighten the screw using a 8mm hex tool. Apply a torque of 8 Nm.



 Repeat steps 4.4. - 4.6. for every panel of the row.

7 Mount the end clamps on the high and low base of the last panel of the row and tighten the screw using a 8mm hex tool. Apply a torque of 8 Nm.

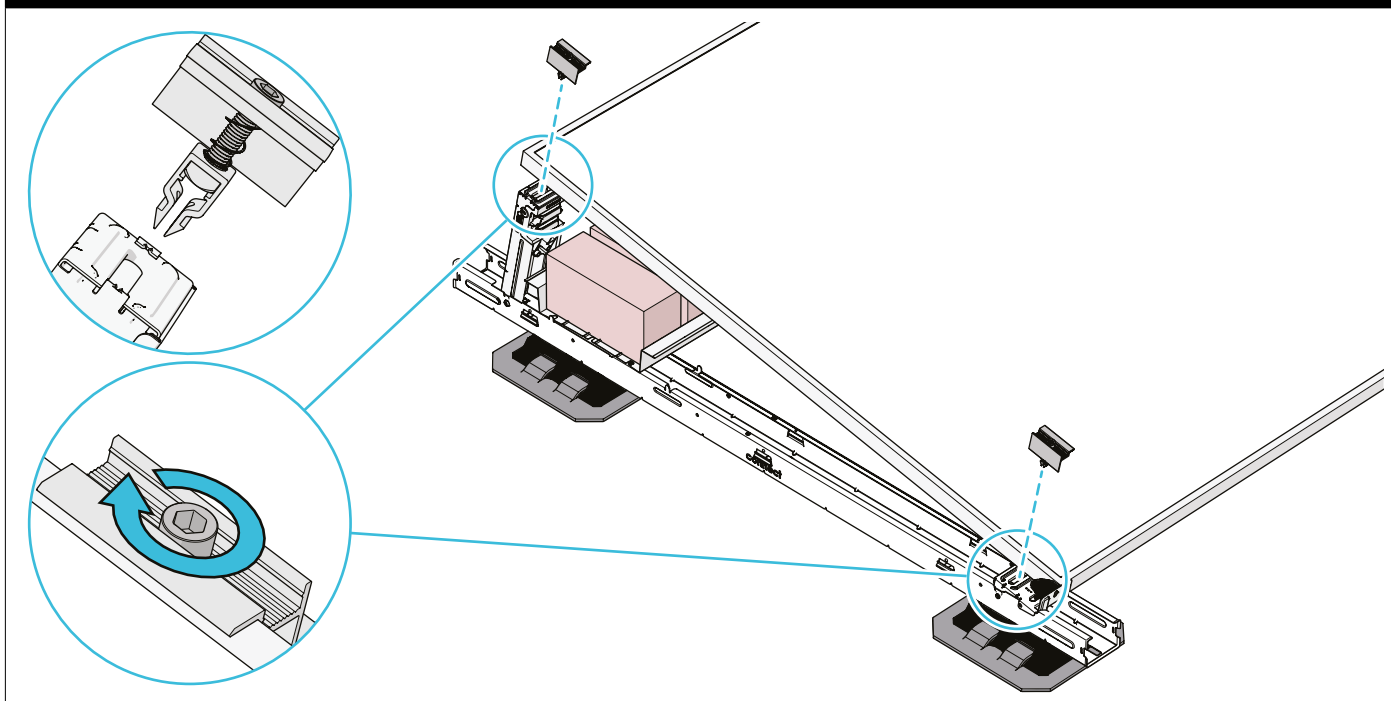

8 Attach a grounding cable to the high base (A) or base element (B) of each solar panel field.

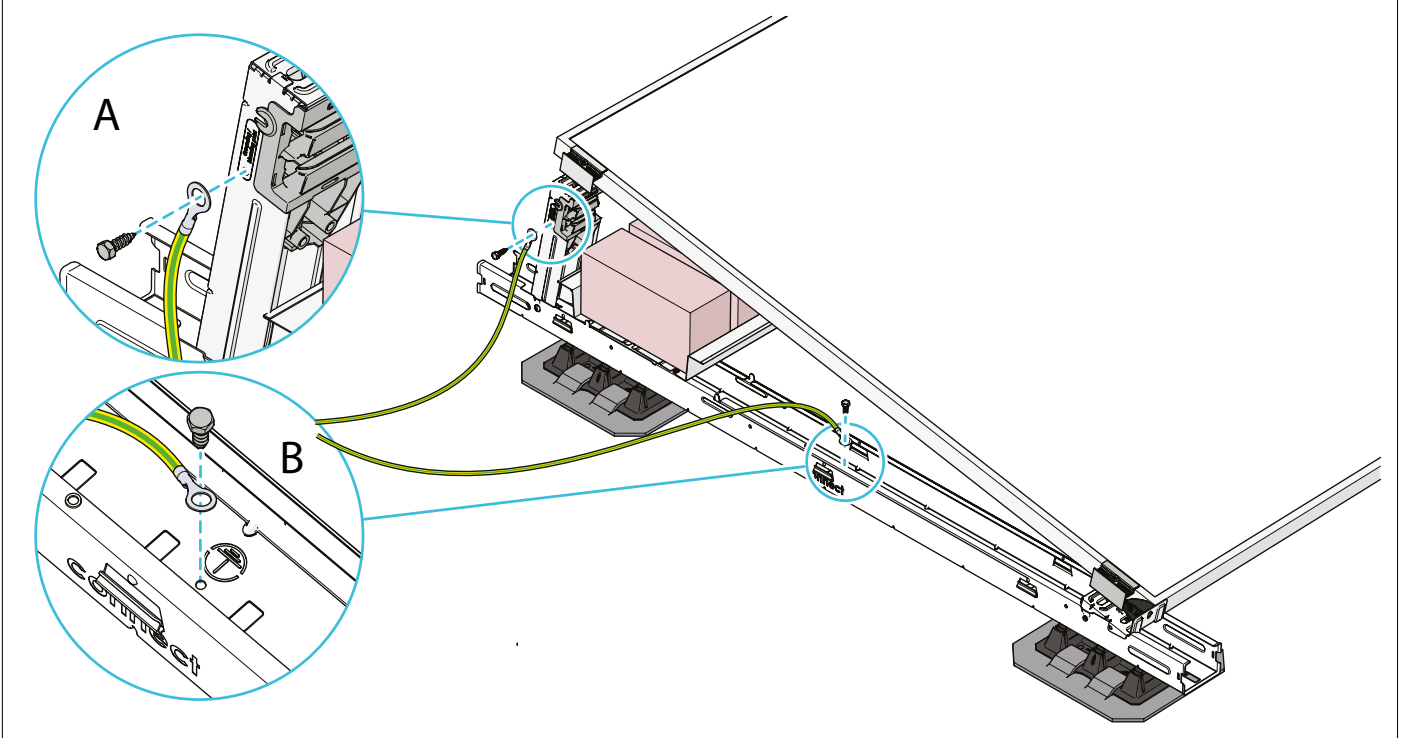

5. PLACING BACK PLATES

- 1 Place the back plate in the designated slots in the high bases and tilt the back plate up against the high base.

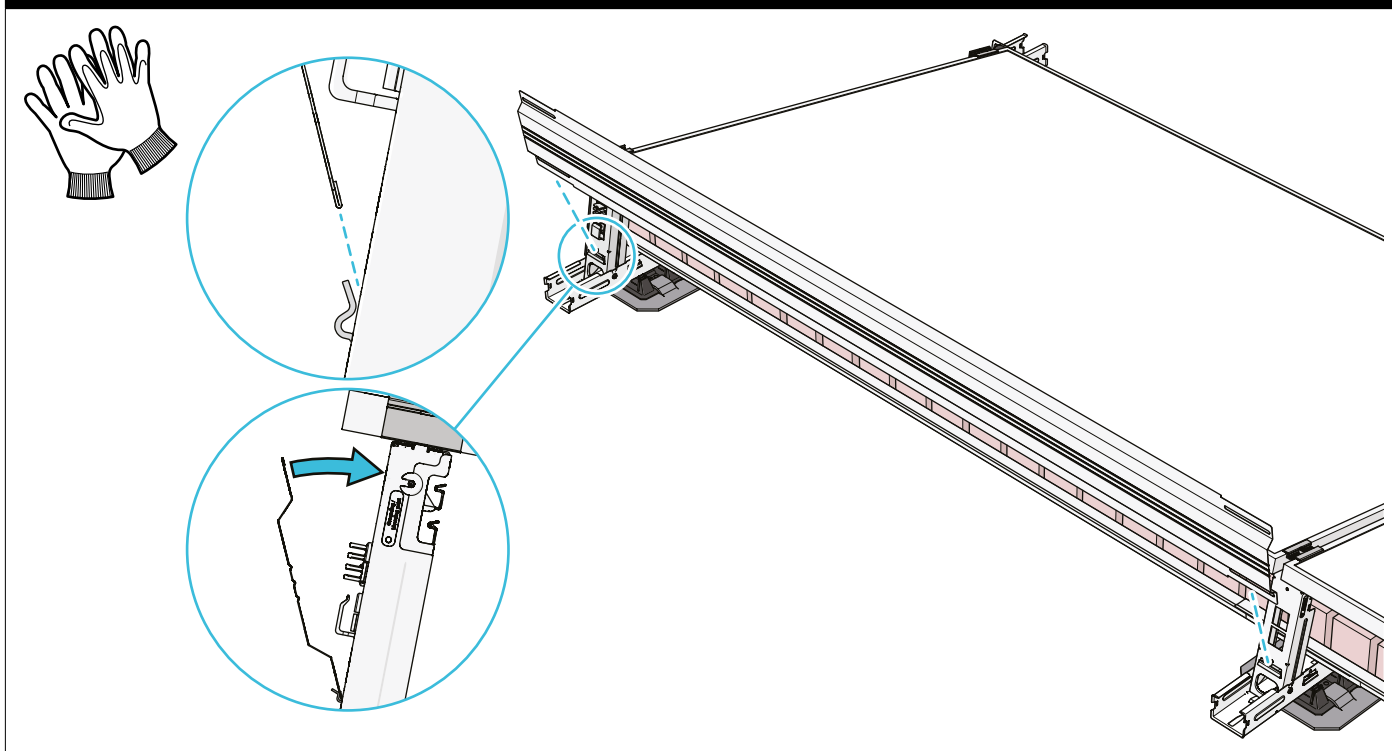

- 2 Align the back plate with the high base
- 3 Secure the back plate to the first high base with two cladding screws. Use a 3/8" socket.

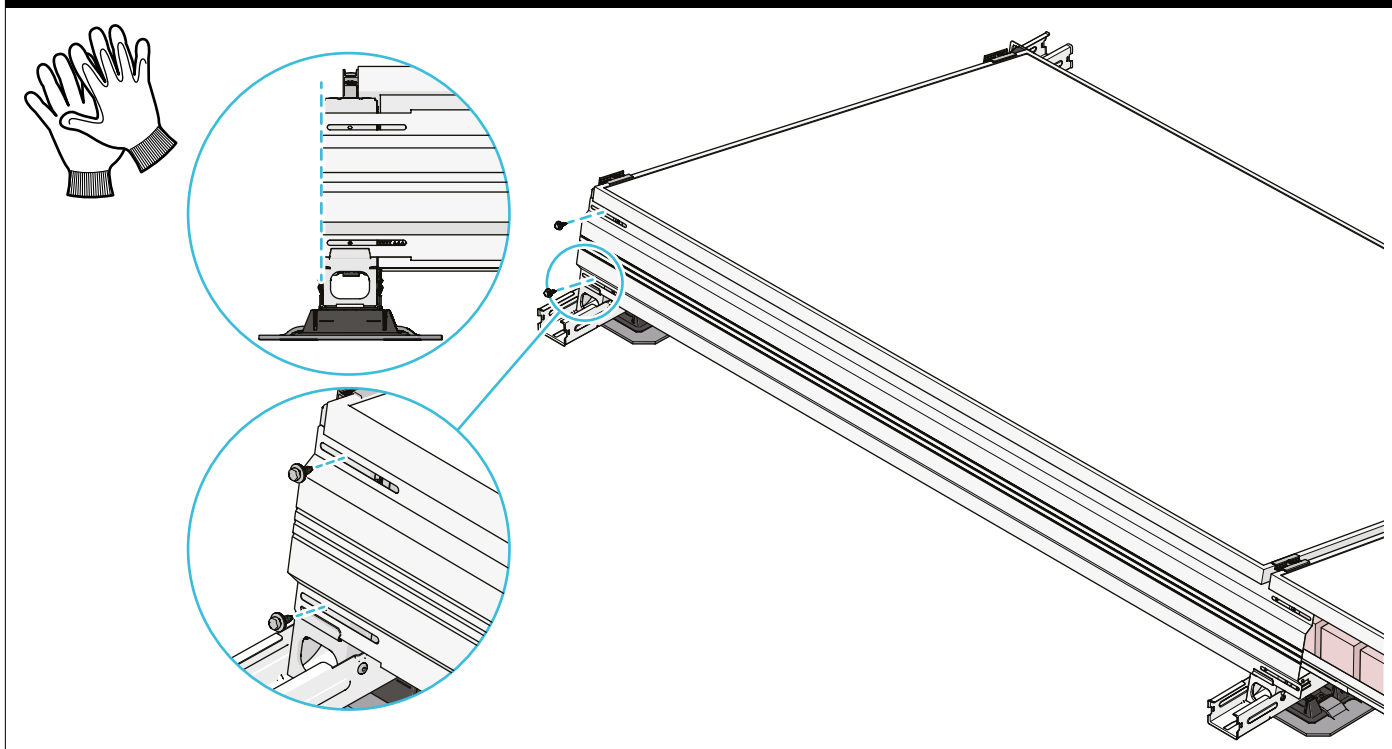

- 4 Place the next back plate in the designated slots in the high bases.
- 5 Tilt the back plate up and align the back plate with the solar panel, overlapping the first back plate.
- 6 Secure both back plates to the high base with two cladding screws. Use a 3/8" socket.

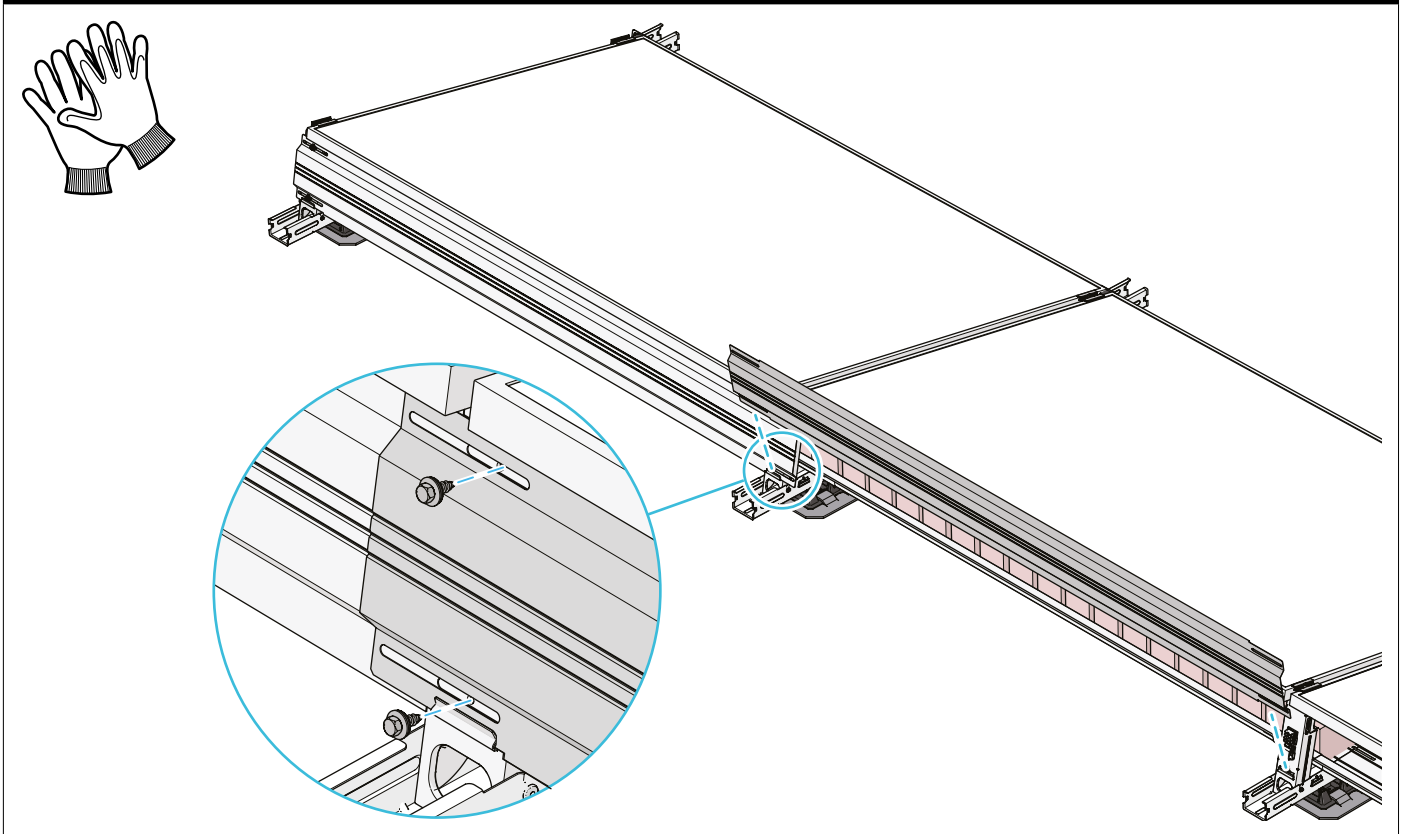

Repeat the steps in this chapter for all back plates.

6. INSTALLING SIDE DEFLECTORS

- 1 Place the side deflector in the designated slots in the base element and align the holes in the deflector to the notches in the base element.
- 2 Insert the cable grommet into the side deflector.

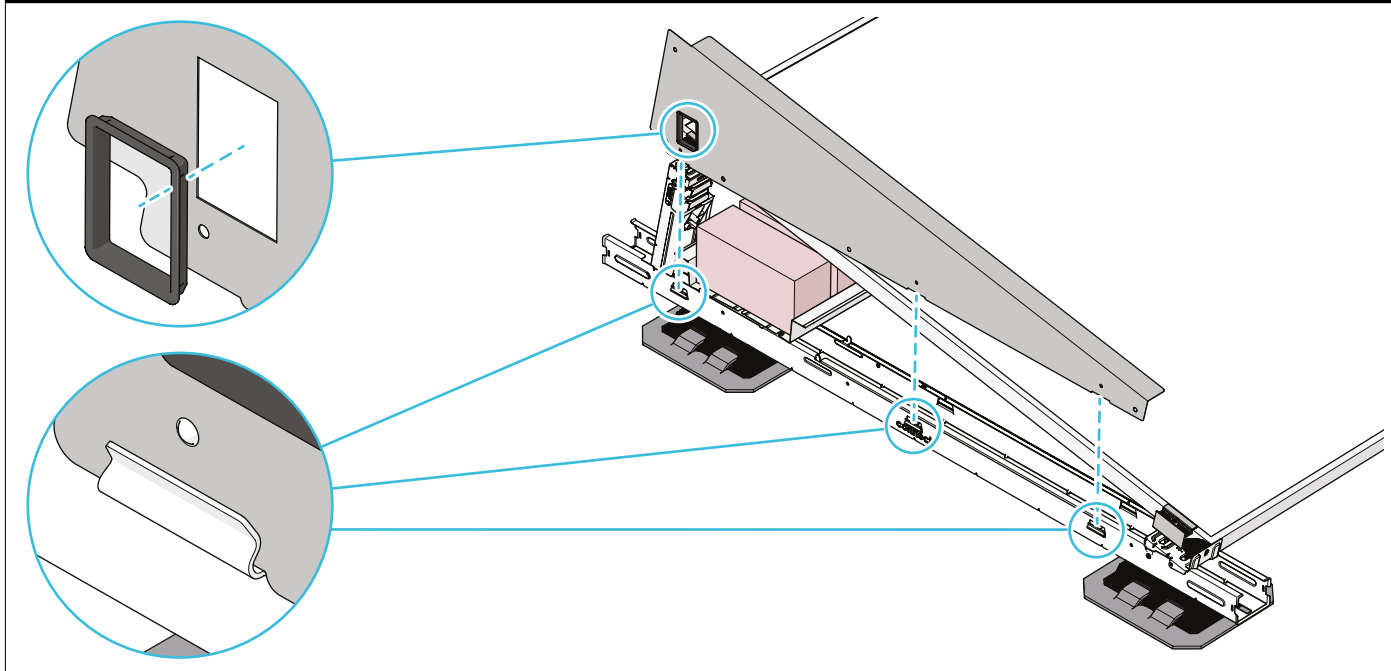

- 3 Secure the side deflector to the base element and high base with two cladding screws. Use a 3/8" socket.

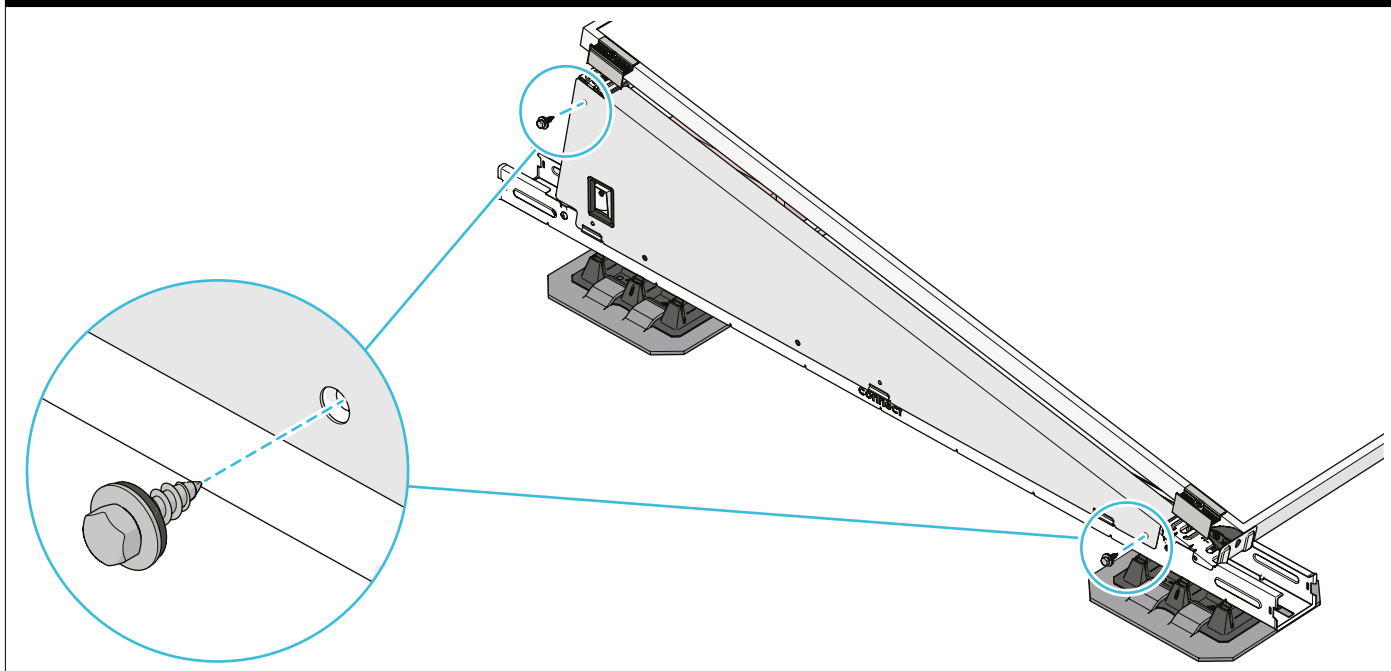

Repeat the steps in this chapter for all side deflectors.

7. PLACING END CAPS

- 1 Optional: if you are going to install end caps on the outer base elements of the segment, move the foot at the low base of the first base element in the row one slot backwards.

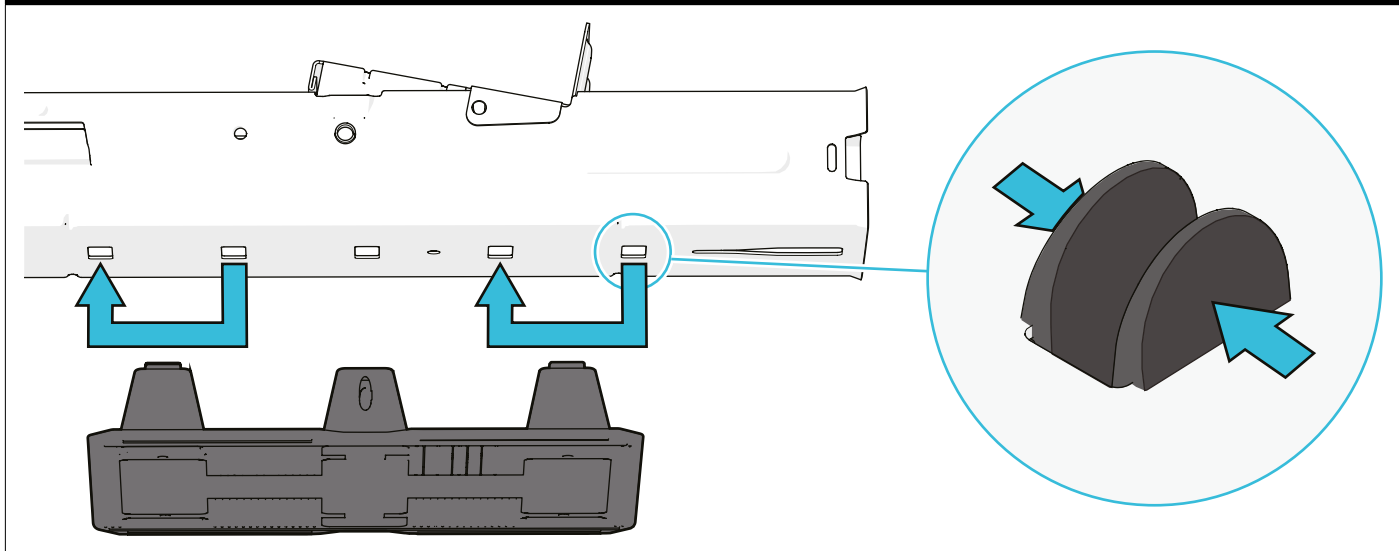

- 2 Optional: Place end caps on the first and last base elements of every row.

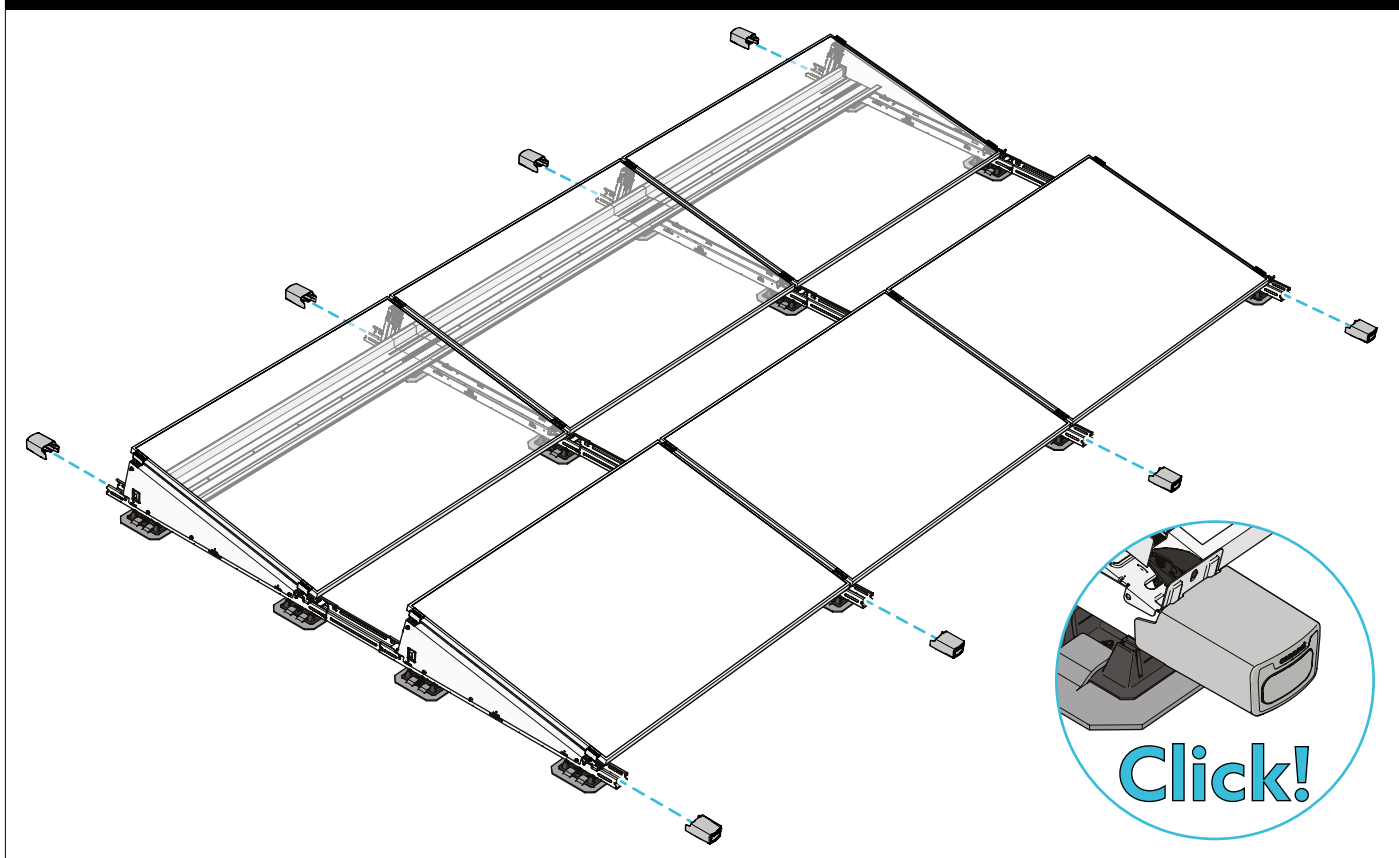

ANNEXES

A. Cable management

1 Mount the optimizer to the predrilled screw hole of a base element for every row.

i If two ballast trays are installed on the base element, drill a hole next to the ballast trays in the base element and mount the optimizer to the base element.

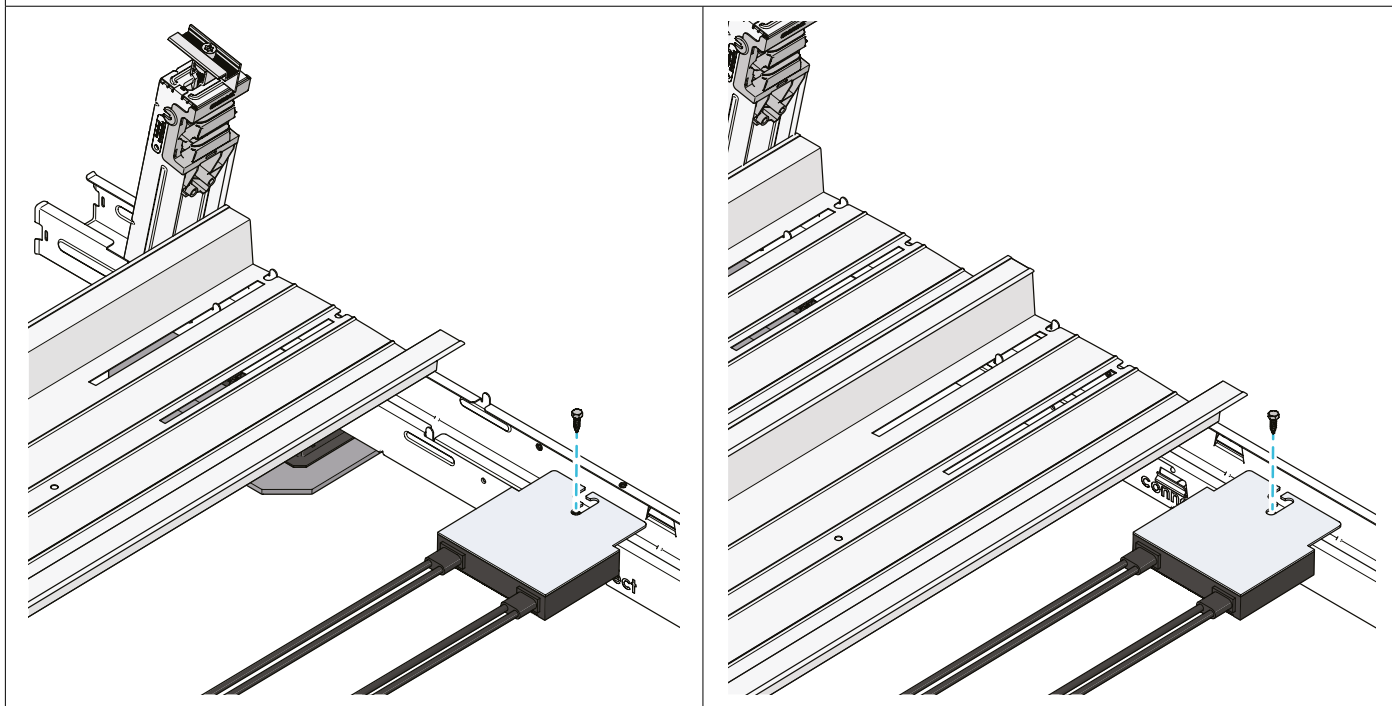

2 Guide the solar panel cables through cable guides at the front of the high bases.

3 Feed the return cable through the hole at the bottom of the high base.

4 Guide the return cable along the cable guides at the back of the high bases.

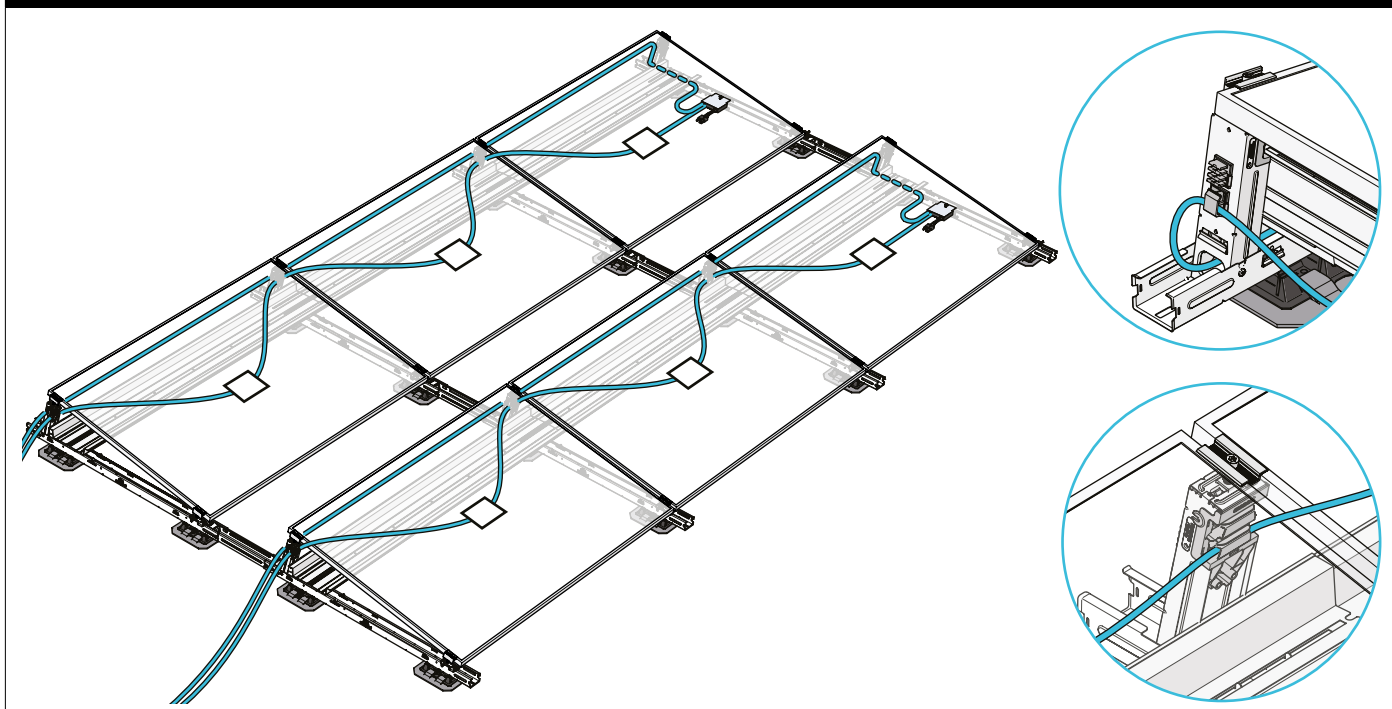

B. Spare parts list

Generic name	Art. Code	Description
Base element	500175	Connect base element, landscape, pw=1130-1150, Magnelis
Ballast tray	500530	Connect ballast tray, landscape, pl=1663-1778, L=1901, Magnelis
	500531	Connect ballast tray, landscape, pl=1779-1894, L=2017, Magnelis
	500532	Connect ballast tray, landscape, pl=1895-2010, L=2133, Magnelis
	500533	Connect ballast tray, landscape, pl=2011-2126, L=2249, Magnelis
	500500	Connect ballast tray, portrait, pw=1035-1150, L=1273, Magnelis
Back plate	500240	Connect back plate 72-cell panels
	500245	Connect back plate 72-cell panels large
	500236	Connect back plate landscape 66-cells
	500250	Connect back plate landscape large
	500230	Connect back plate landscape small
	500231	Connect back plate portrait
	500232	Connect back plate portrait large
Mid clamp	852630	Easy mid clamp 26-30 mm
	853540	Easy mid clamp 35-40 mm
End clamp	860030	Easy end Clamp 30mm
	860035	Easy end clamp 35mm
Side deflector	500135	Connect side deflector, landscape, left, Magnelis
	500136	Connect side deflector, landscape, right, Magnelis
Connector	500050	Connect connector East West Setup
	500013	Connect connector 1320
	500015	Connect connector 1500
	500017	Connect connector 1700
Grommet	500005	15) Connect cable grommet
Leveling block	500810	16) Connect leveling block
End cap	220293	17) Connect end cap
Screw	500901	Connect cladding screw
Friction mat	140920	18) Connect friction mat
	140930	Connect friction mat, PVC
SolarSteller	500001	19) Connect Solarsteller
	500011	20) Connect Solarsteller



blubase™

Siegenstraat 5 | 8028 PT Zwolle

t. +31 (0)85 80 00 501 | e. info@blubase.com

www.blubase.com